

GROUP H

FUEL SYSTEM - Fuel tank. All 109in 4 cyl. models from Vehicle suffix 'C' onwards

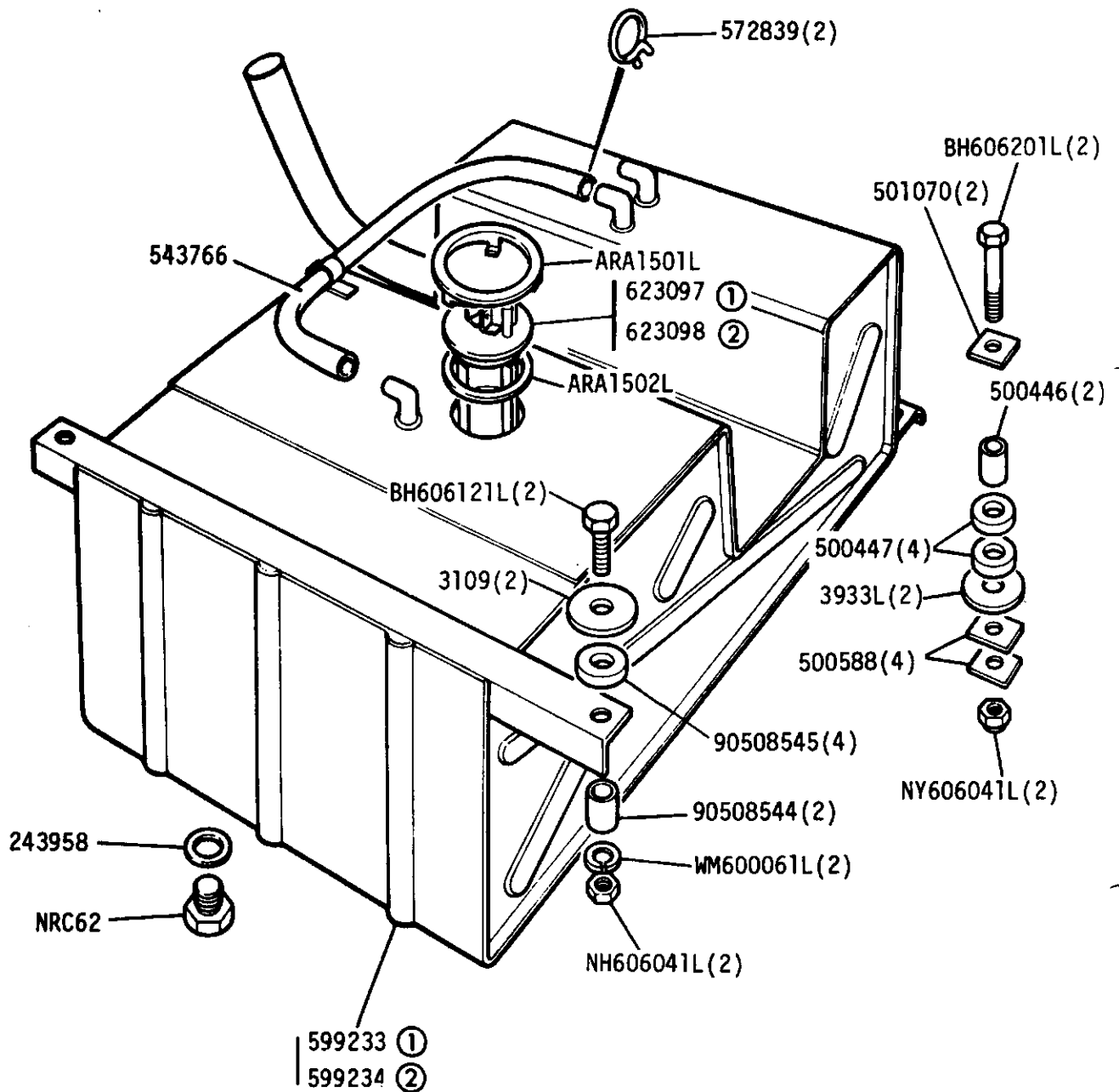

- ① Petrol
- ② Diesel

GROUP H
 FUEL SYSTEM - Fuel Tank - 2.6 Litre Petrol up to Vehicle suffix 'B' inclusive

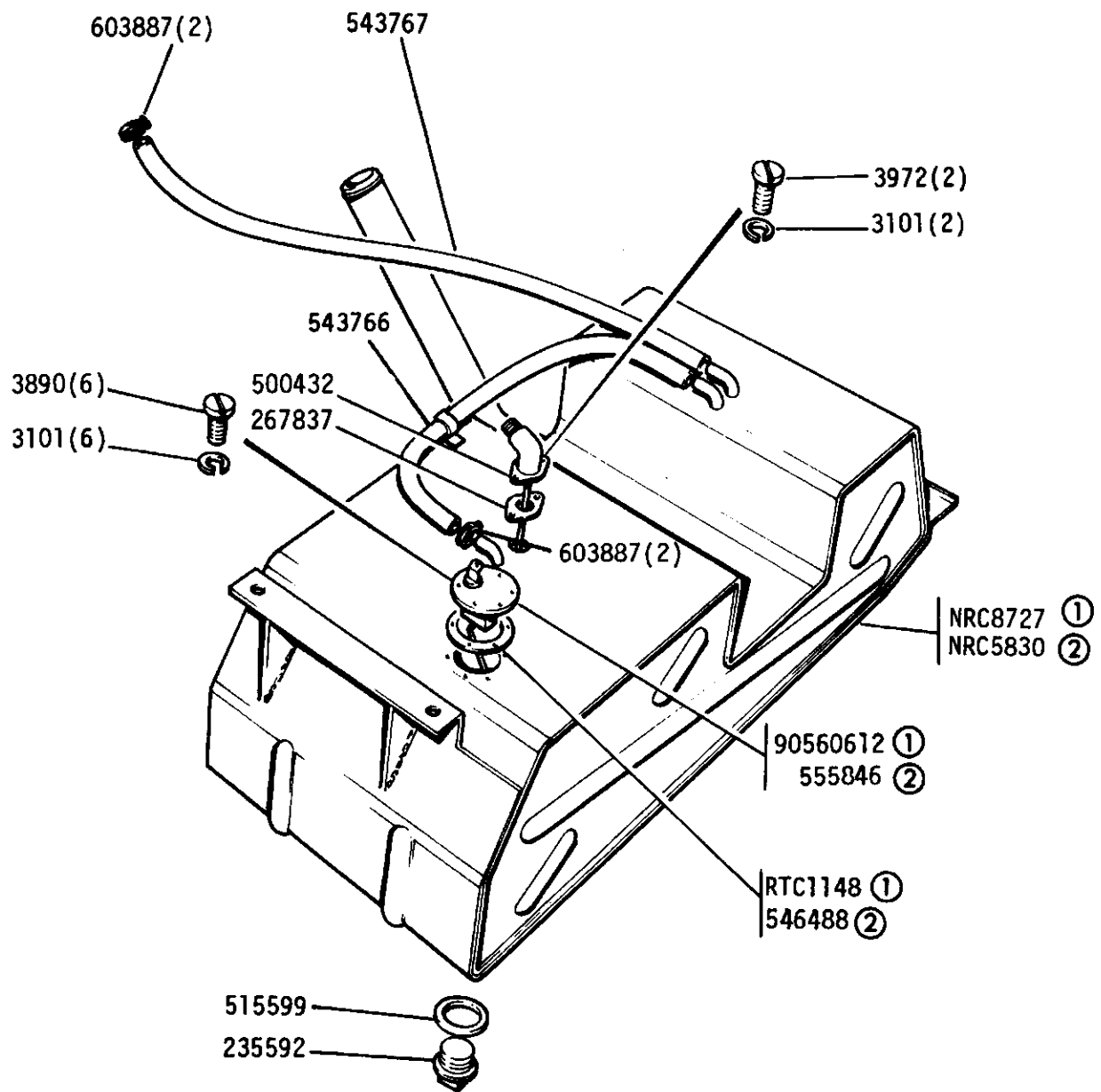

- ① Except Station Wagon
- ② Station Wagon

GROUP H

FUEL SYSTEM - Fuel Tank 2.6 Litre Petrol-From Vehicle Suffix 'C' onwards

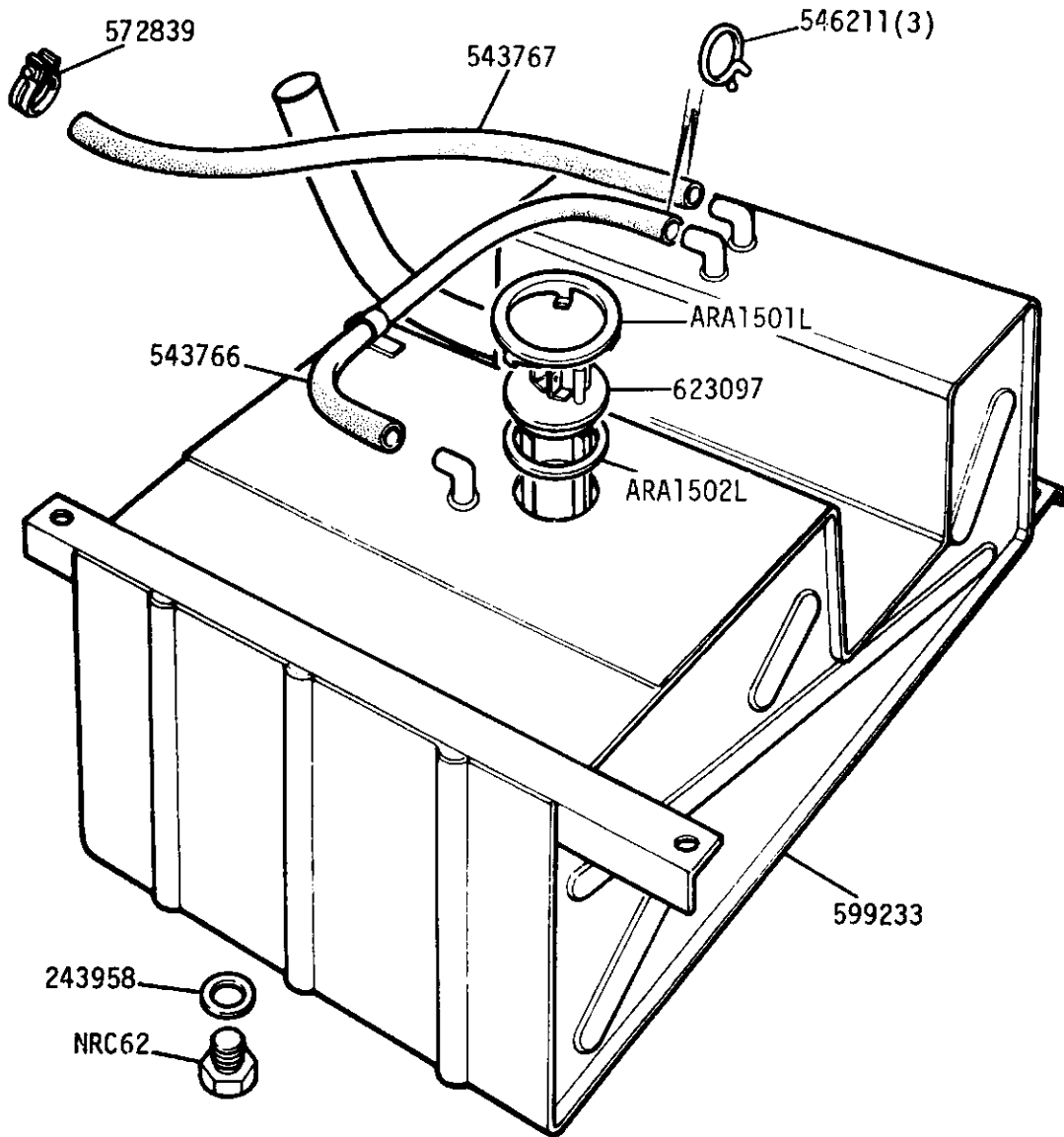

GROUP H
 FUEL SYSTEM - Fuel Tank Mounting - 2.6 Litre Petrol Except Station Wagon up to Vehicle
 suffix 'B' inclusive

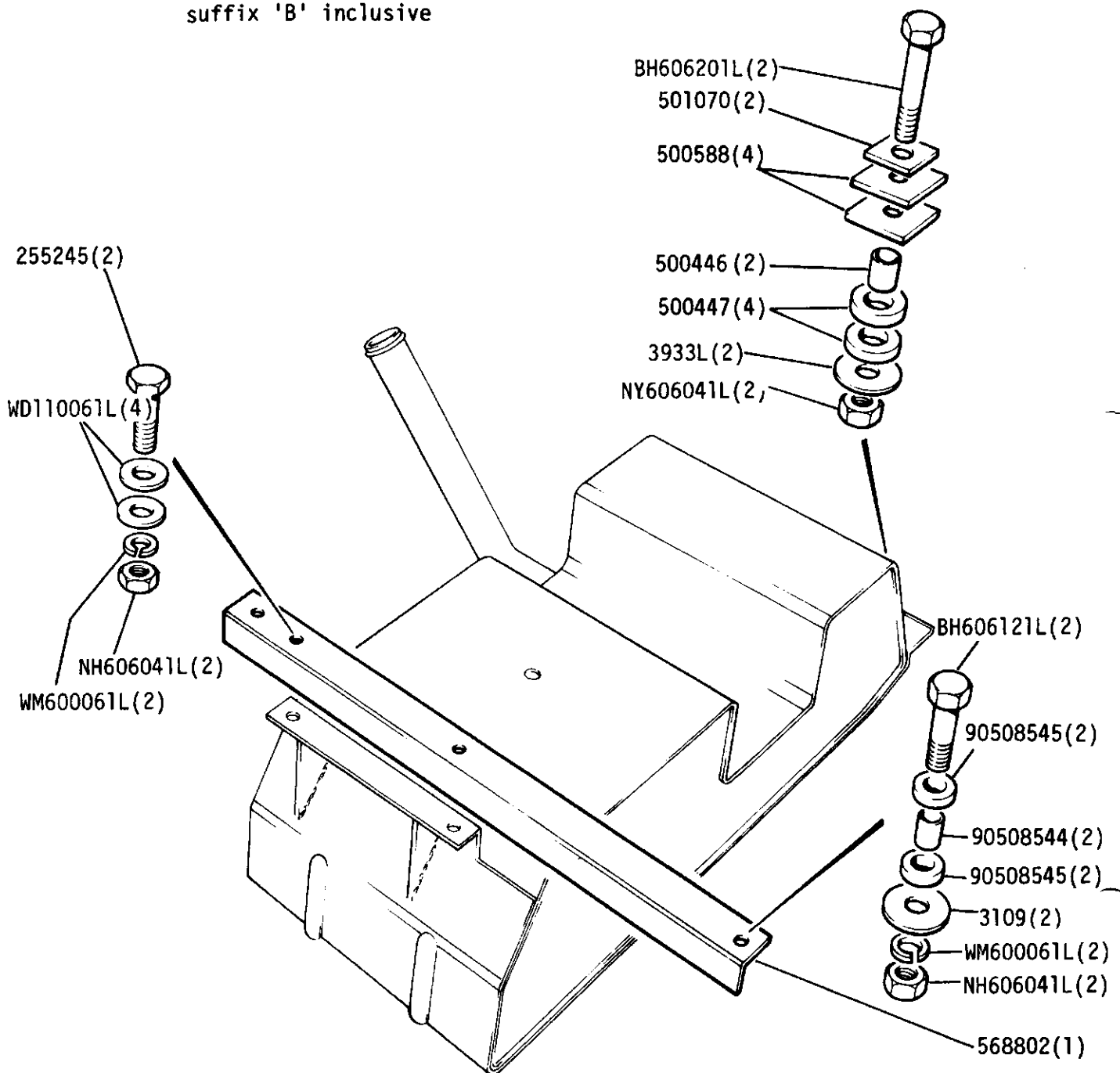

GROUP H

FUEL SYSTEM - Fuel Tank Mountings 2.6 Litre Petrol - Station Wagon up to Vehicle
suffix 'B' inclusive

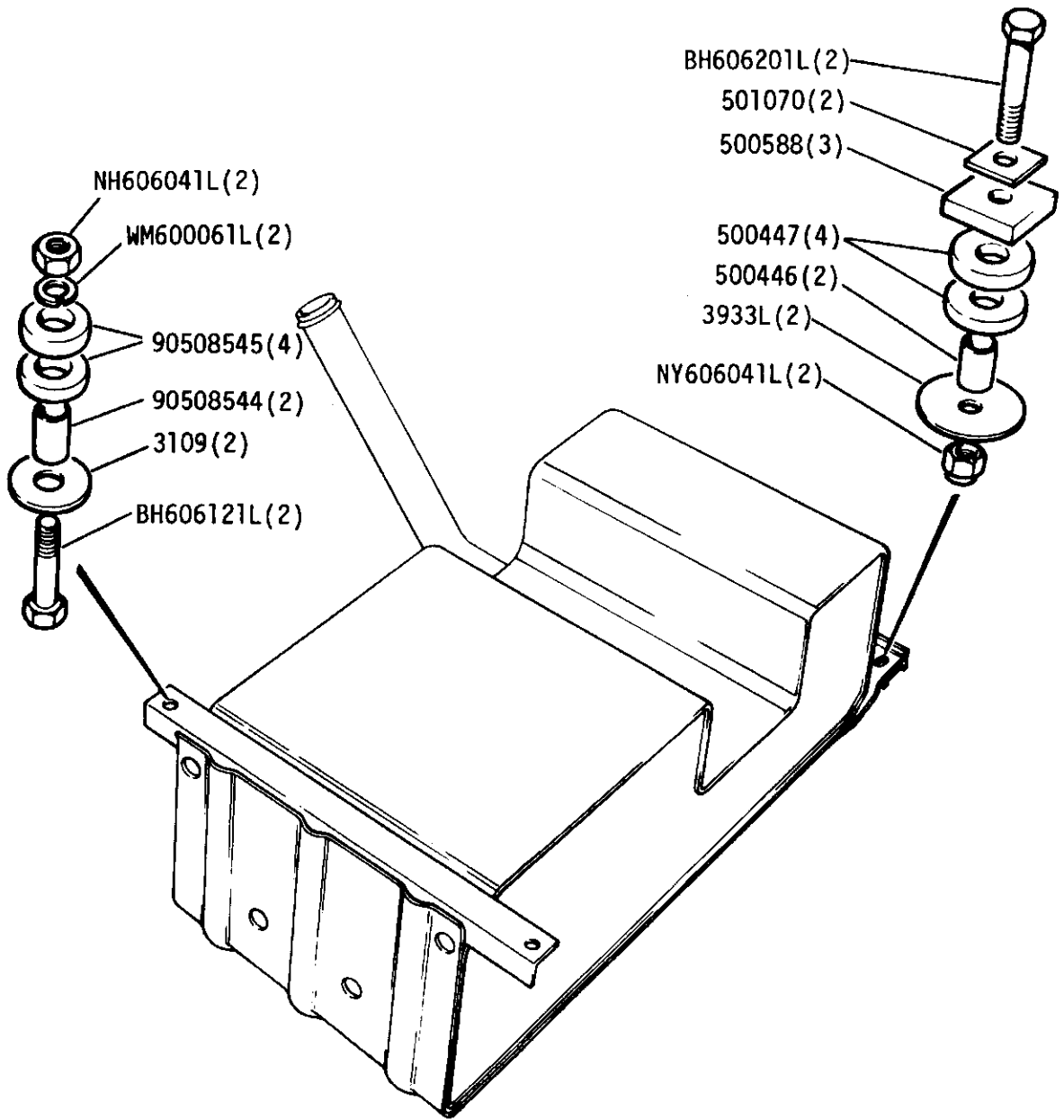

GROUP H

FUEL SYSTEM - Fuel Tank Mountings - All 2.6 Litre Petrol models from Vehicle suffix 'C' onwards

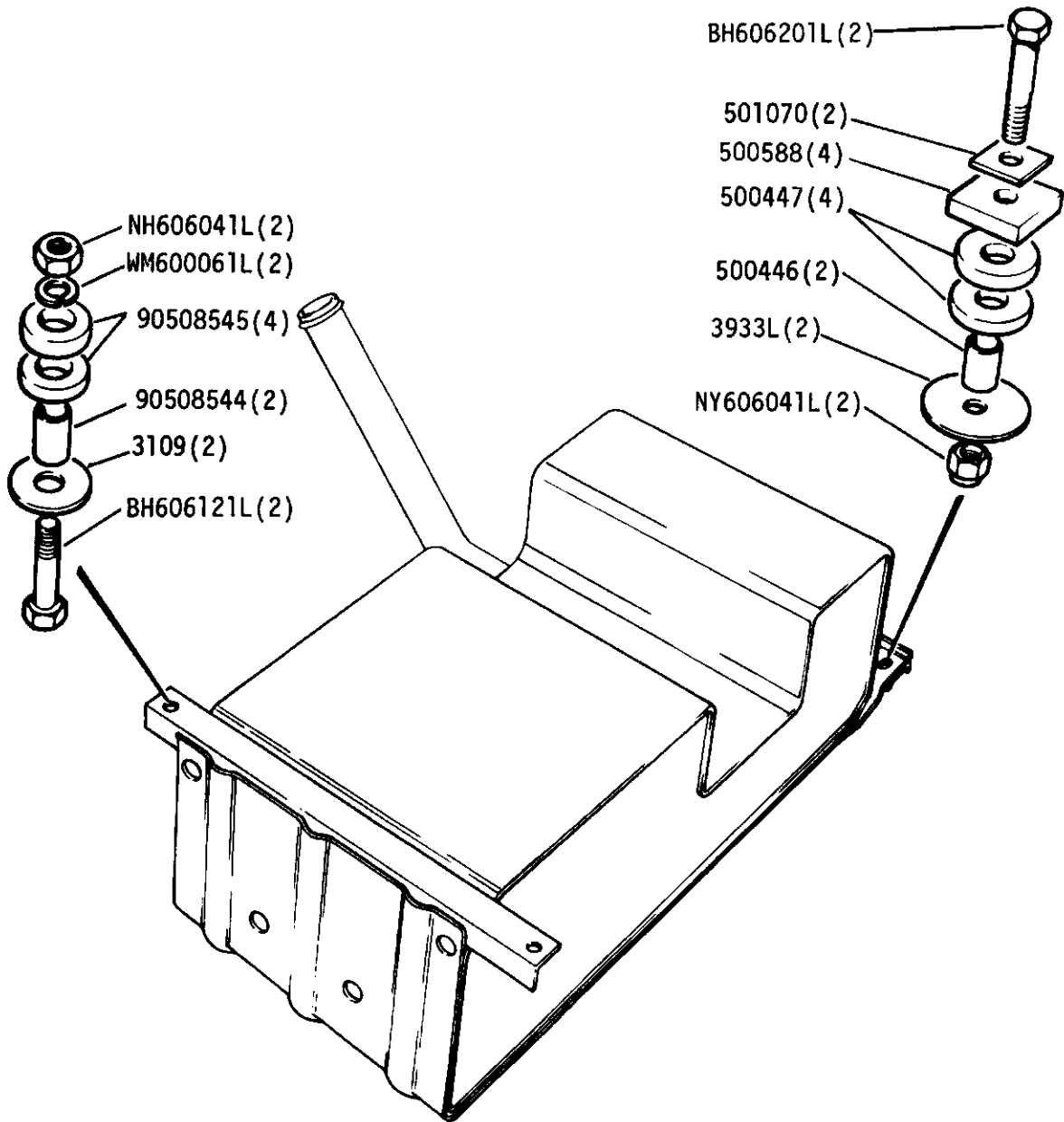

GROUP H
FUEL SYSTEM - Fuel Tank - 109V8

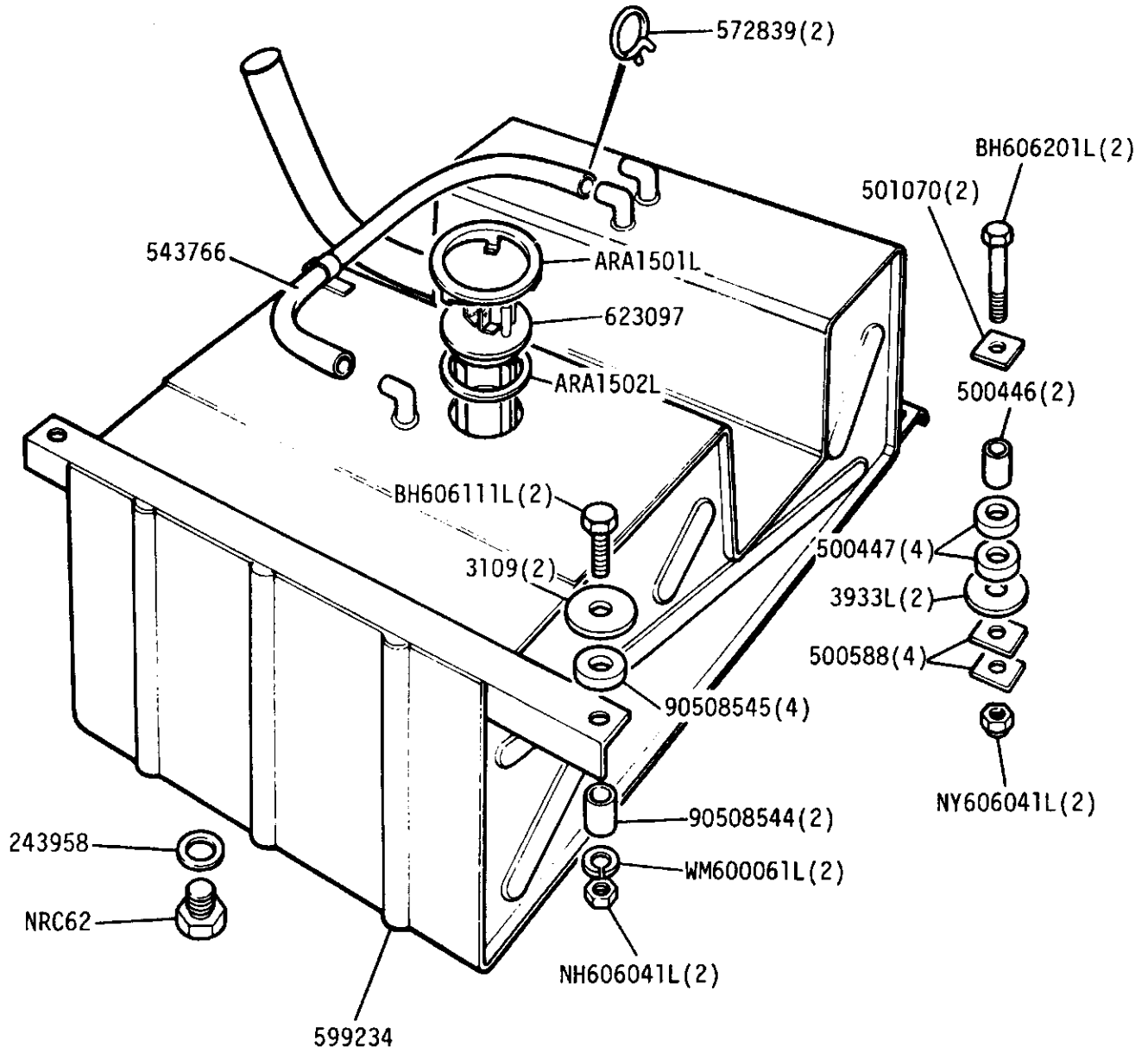

GROUP H

ACCELERATOR - Pedal and Shaft - 2½ Litre Petrol

WP8019L(2) ①

AFU1069(2) ②

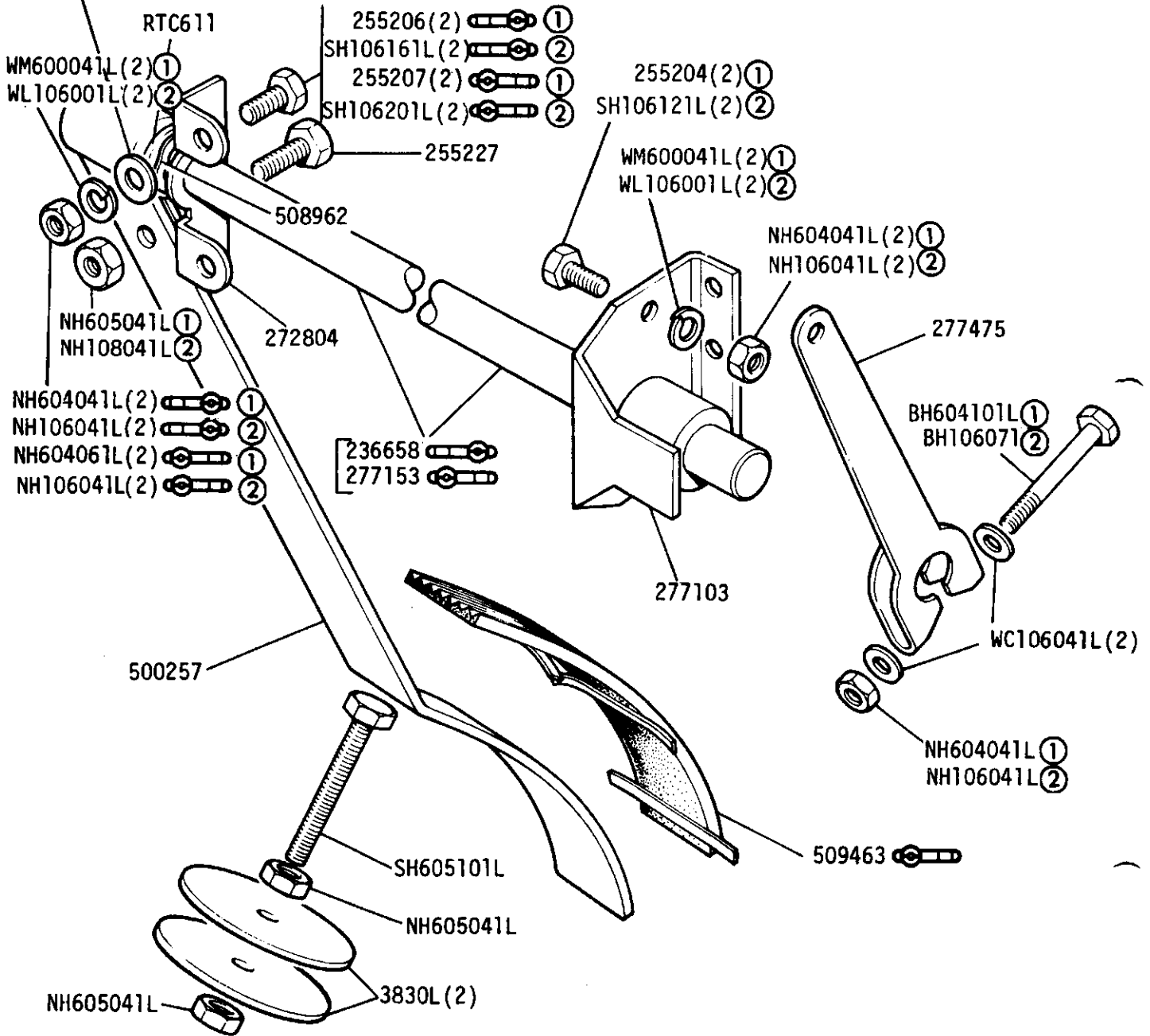

- ① UNF
- ② METRIC

GROUP H
ACCELERATOR - Cross Shaft 2½ Litre Petrol

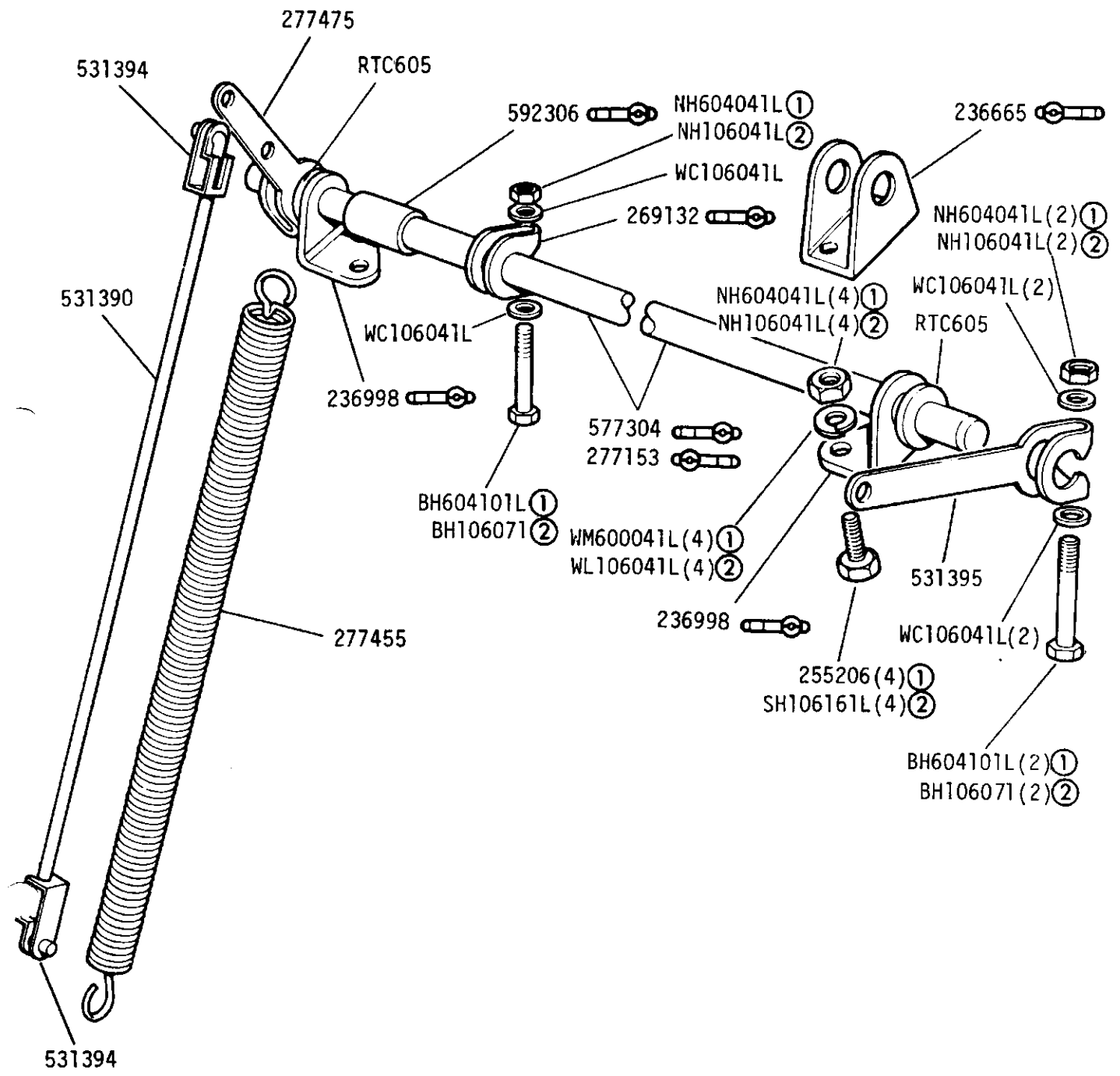

① UNF
② METRIC

LAND ROVER

10 07

2RE 228

GROUP H

ACCELERATOR - Bell Crank and Control Rod 2½ Litre Petrol

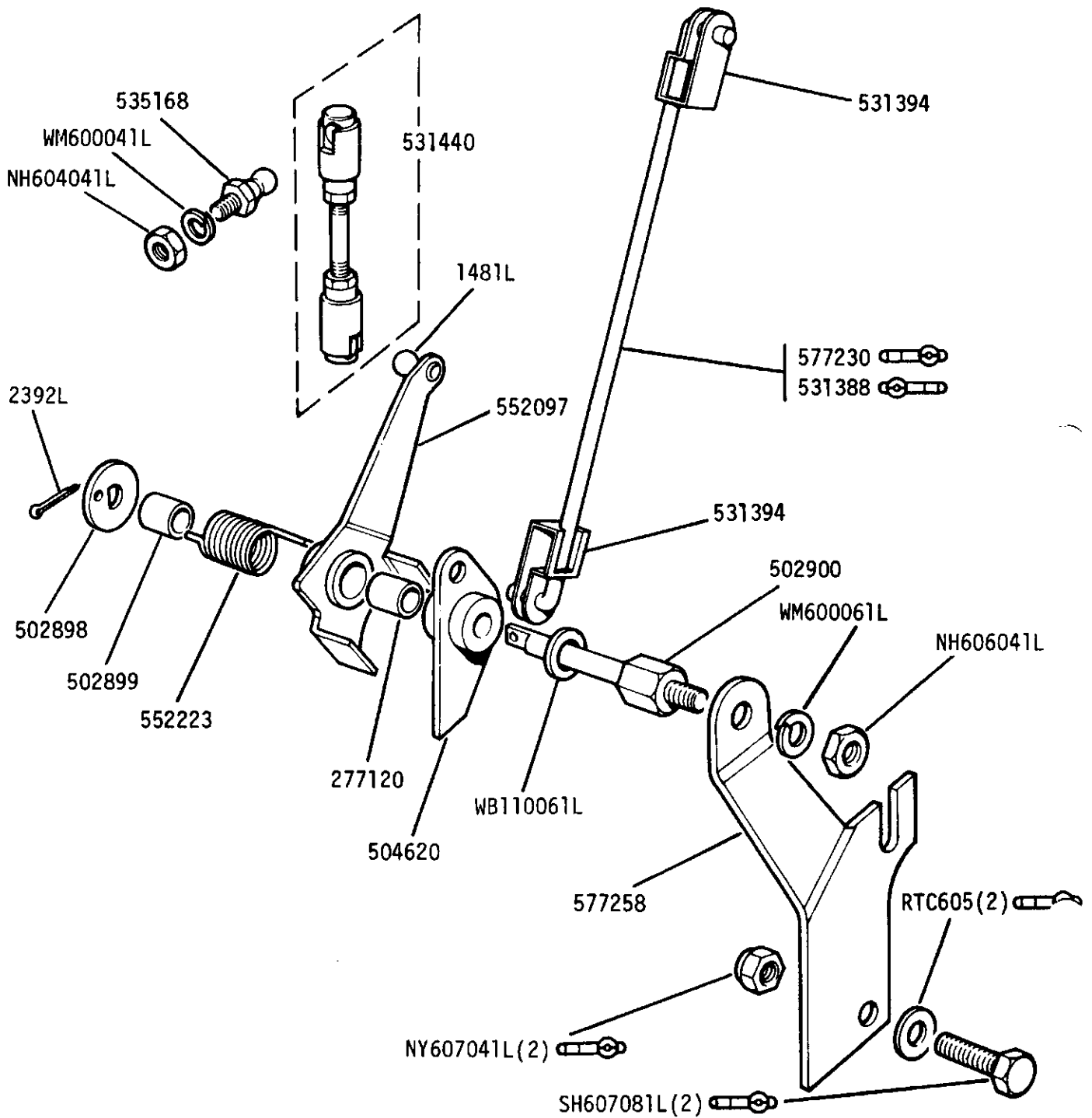

GROUP H
 ACCELERATOR - Pedal and Shaft - 2.6 Litre Petrol

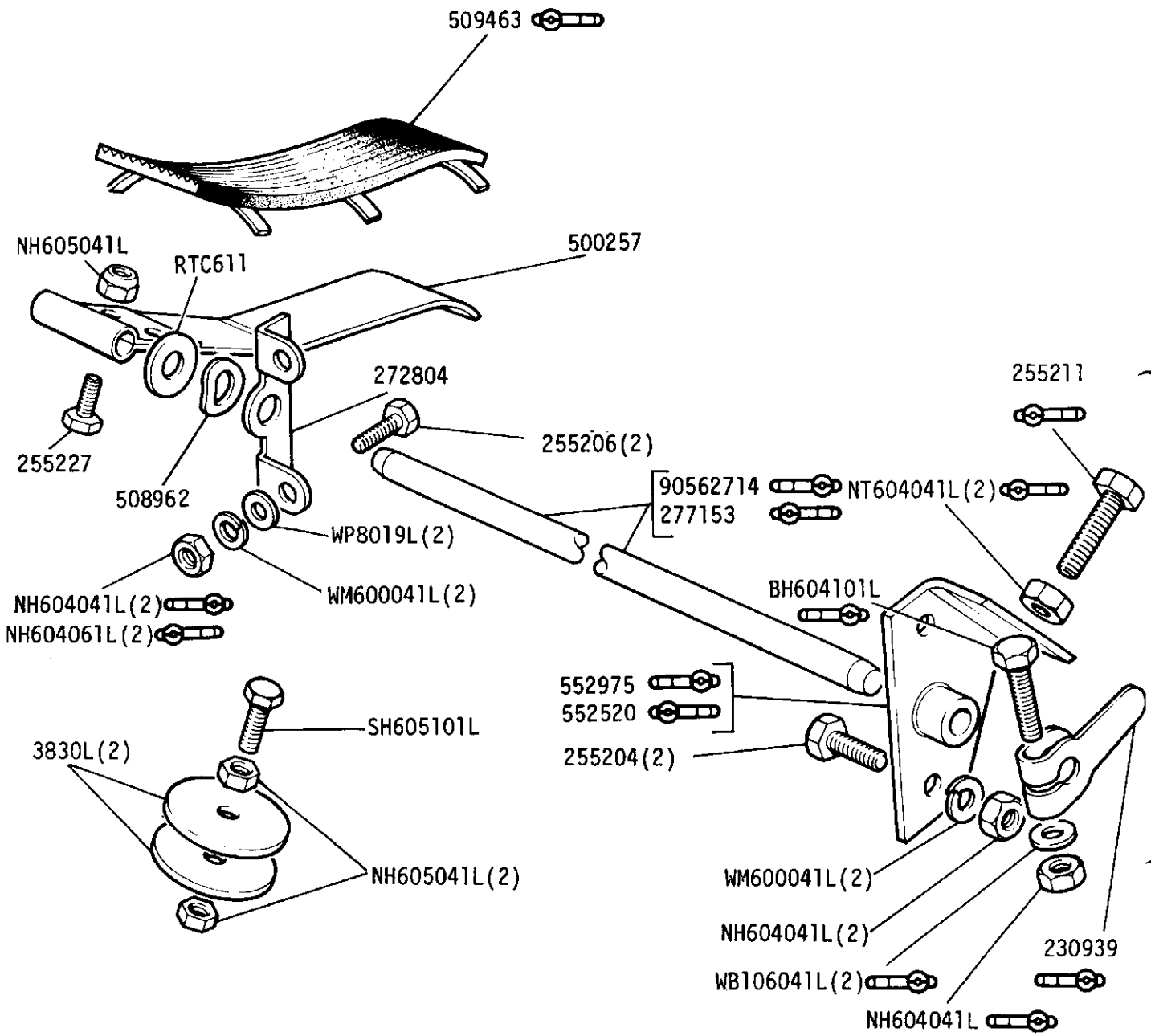

GROUP H
 ACCELERATOR - Cross Shaft and Lever 2.6 Litre Petrol

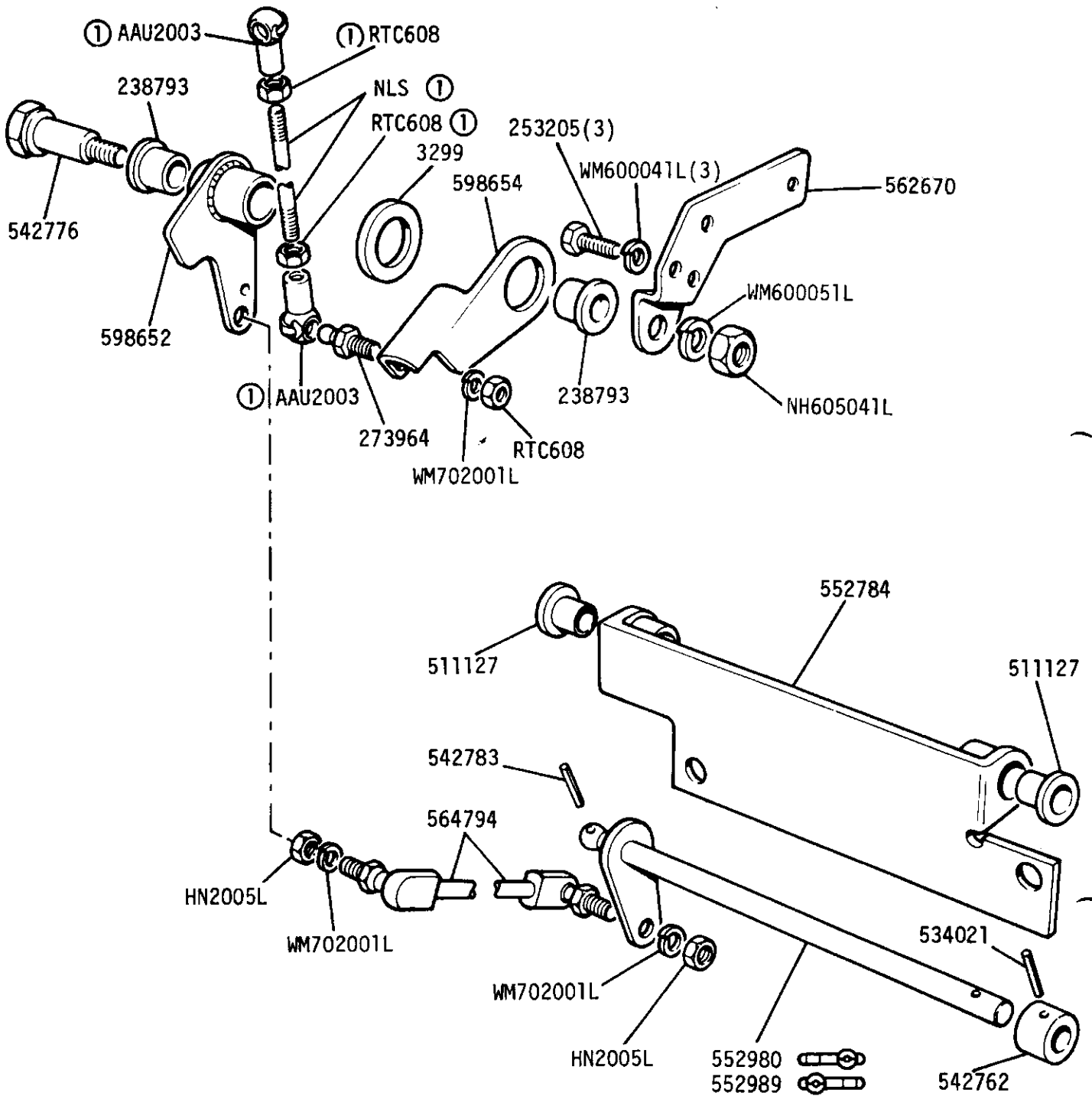

① CONTROL ROD ASSEMBLY 531440

GROUP H

ACCELERATOR - Extension Shaft and Lever 2.6 Litre Petrol

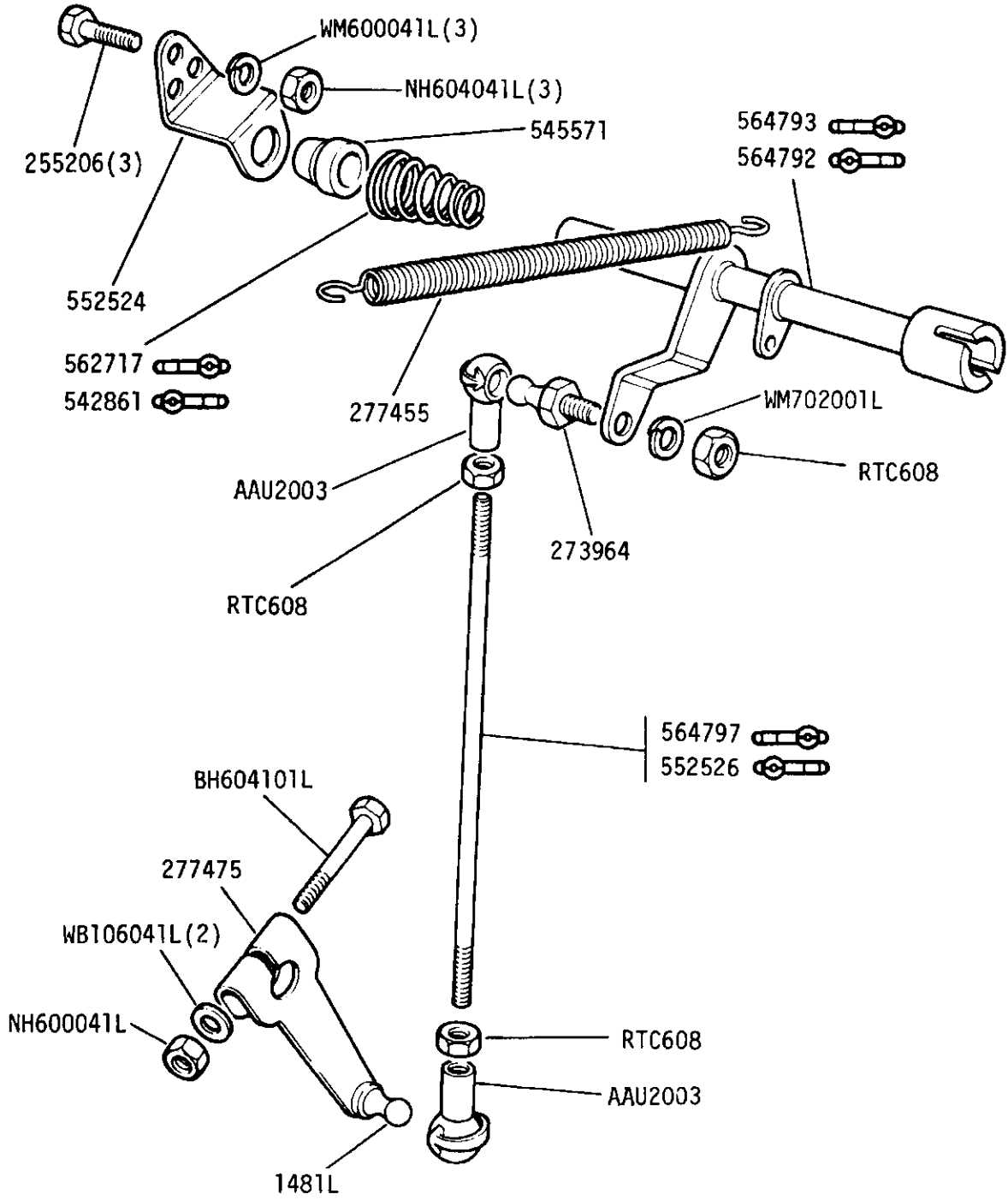

GROUP H
ACCELERATOR - Pedal and Shaft 2½ Litre Diesel

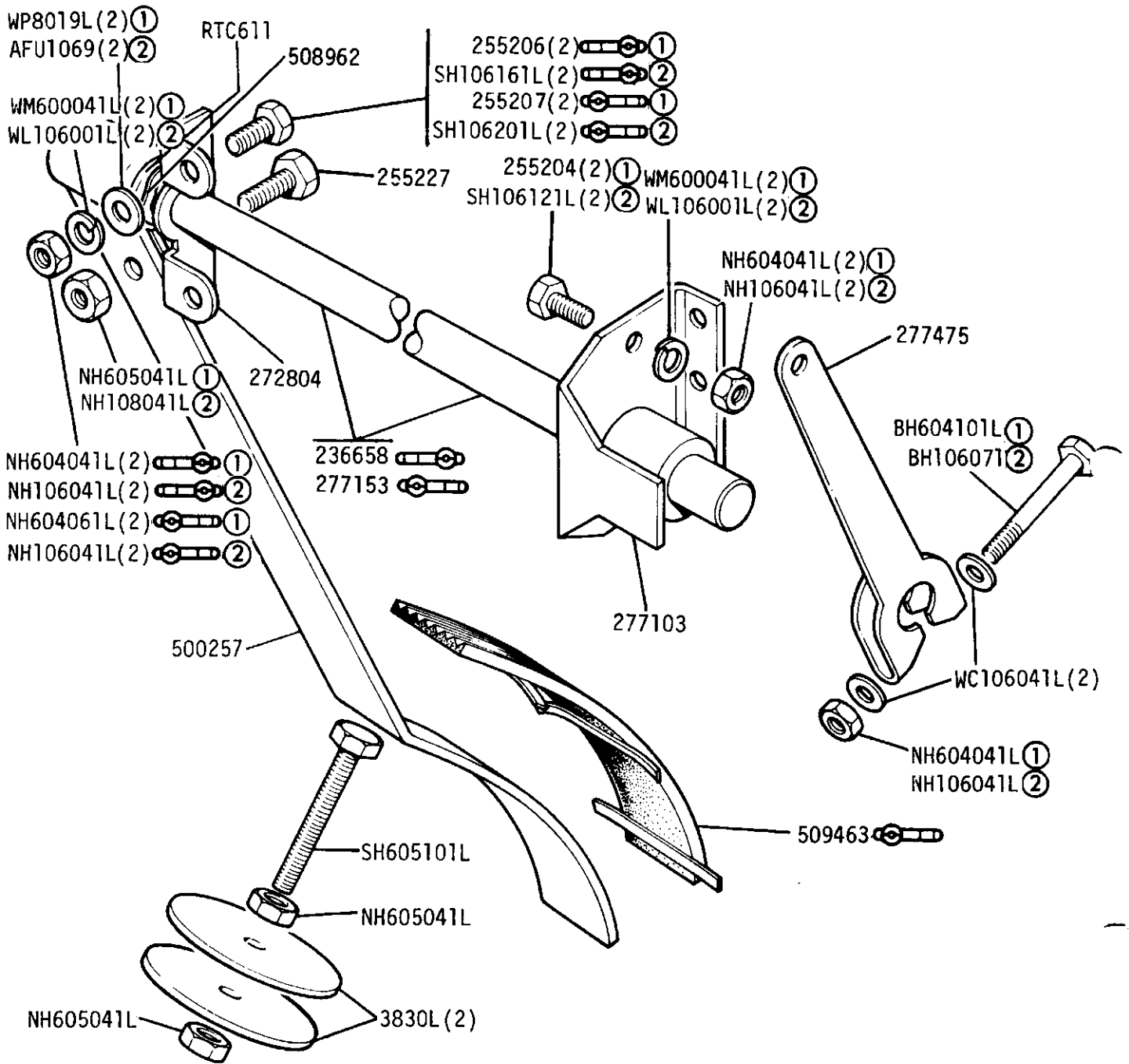

- ① UNF
- ② METRIC

GROUP H

ACCELERATOR - Cross Shaft - 2½ Litre Diesel

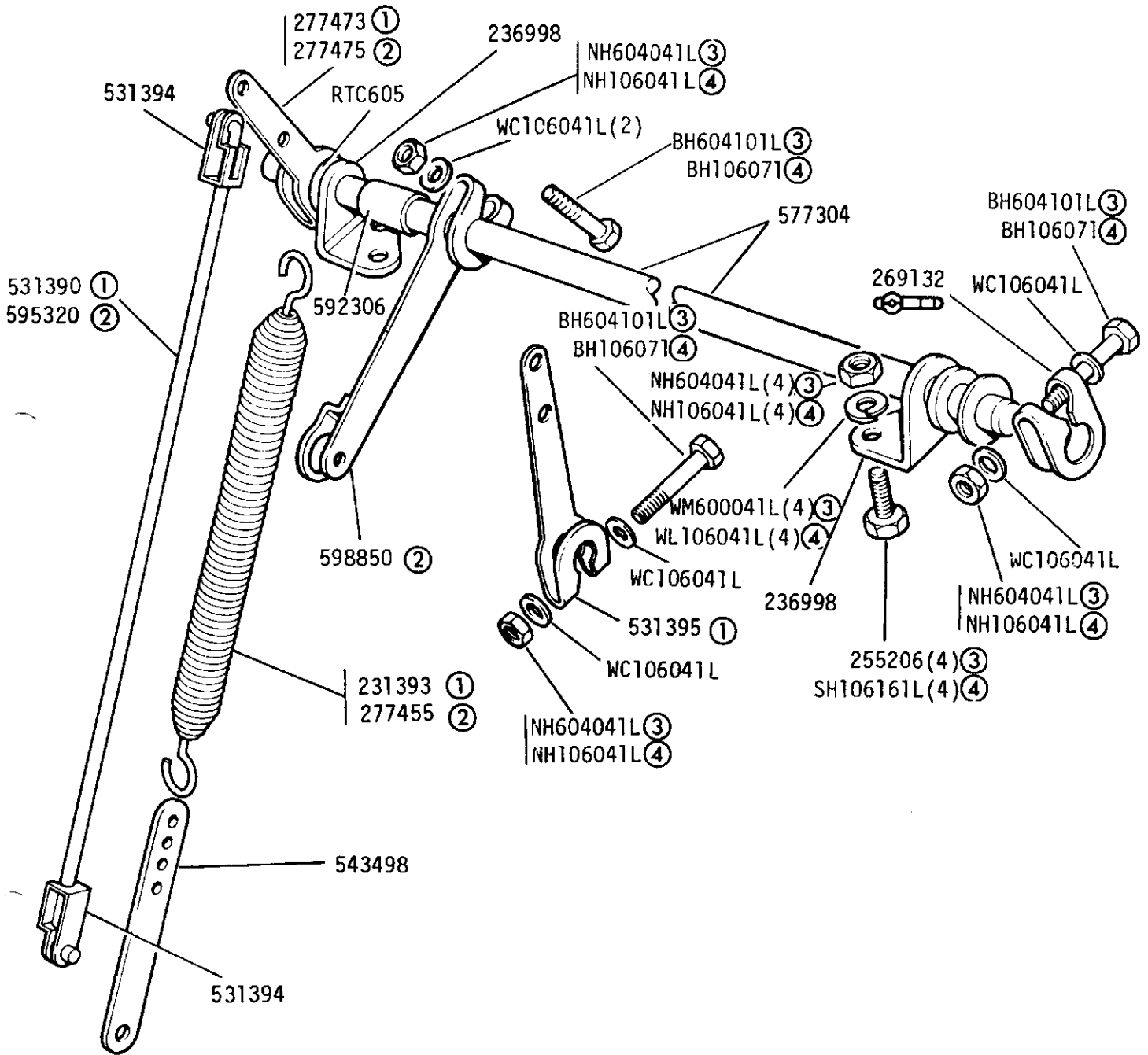

- ① Rod operated throttle
 - ② Cable operated throttle
 - ③ UNF
 - ④ METRIC
- LAND ROVER 10 11 2RE 227

GROUP H
 ACCELERATOR - Rod Operated Controls 2½ Litre Diesel

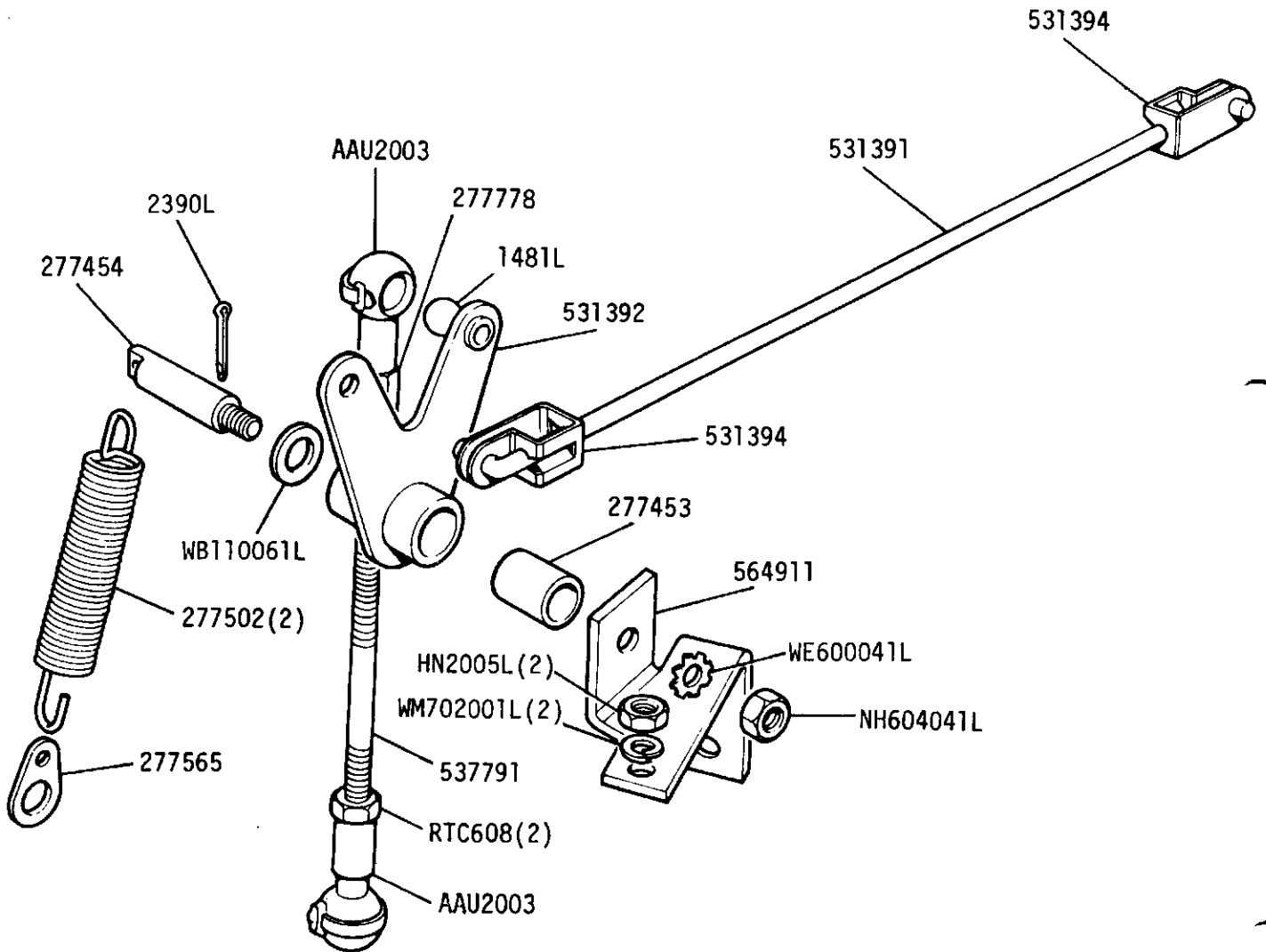

Rod Operated, alternative to Cable operated on adjacent frame

GROUP H
ACCELERATOR - Cable Operated Controls 2½ Litre Diesel

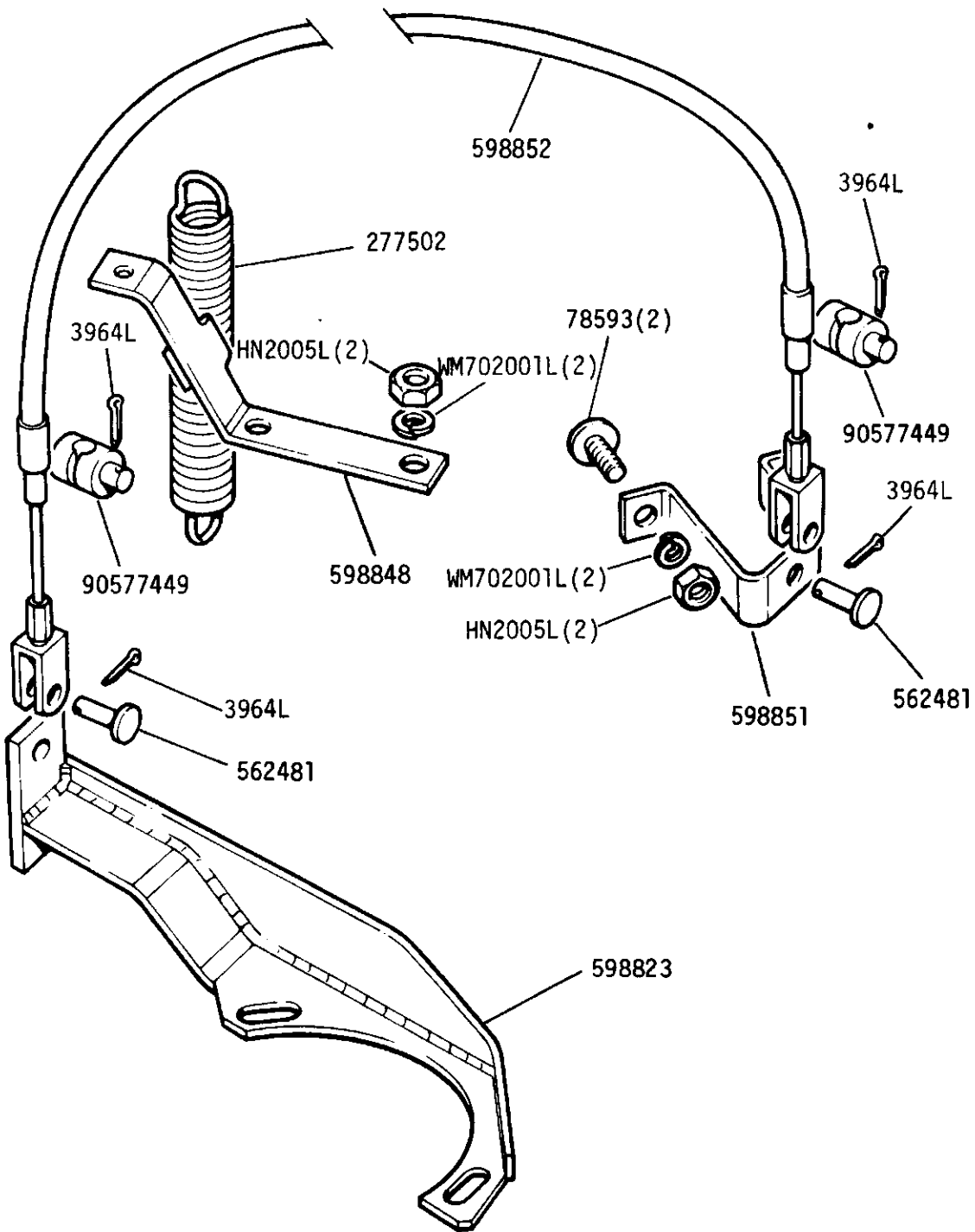

Cable Operated, alternative to Rod operated on adjacent frame

GROUP H
ACCELERATOR - Pedal and shaft, 109V8

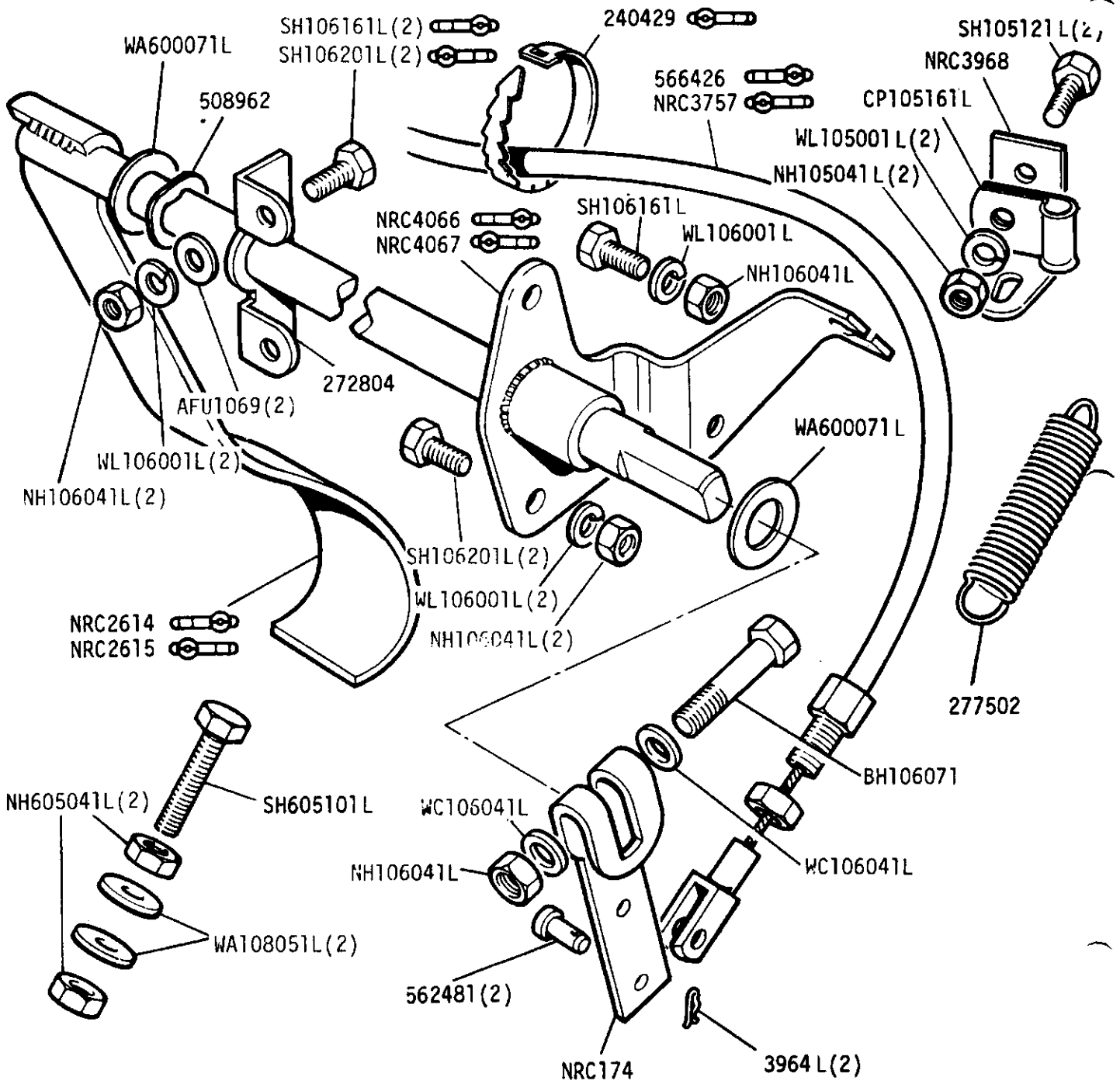

GROUP H
 ACCELERATOR - Engine Speed Hand Control 2½ Litre Diesel

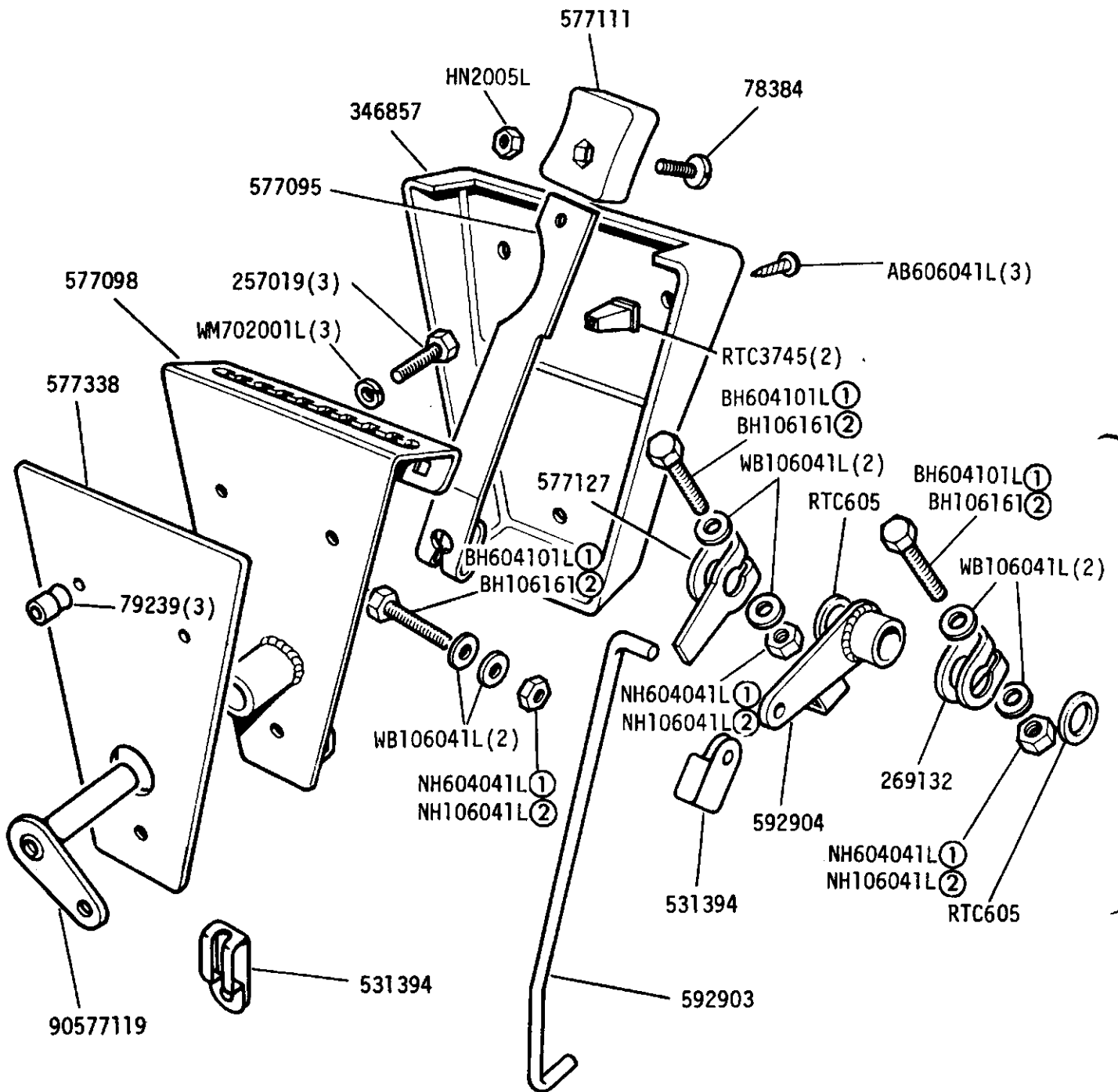

- ① UNF
- ② METRIC

GROUP H
ELECTRICAL - Cold Start and Engine Stop Controls

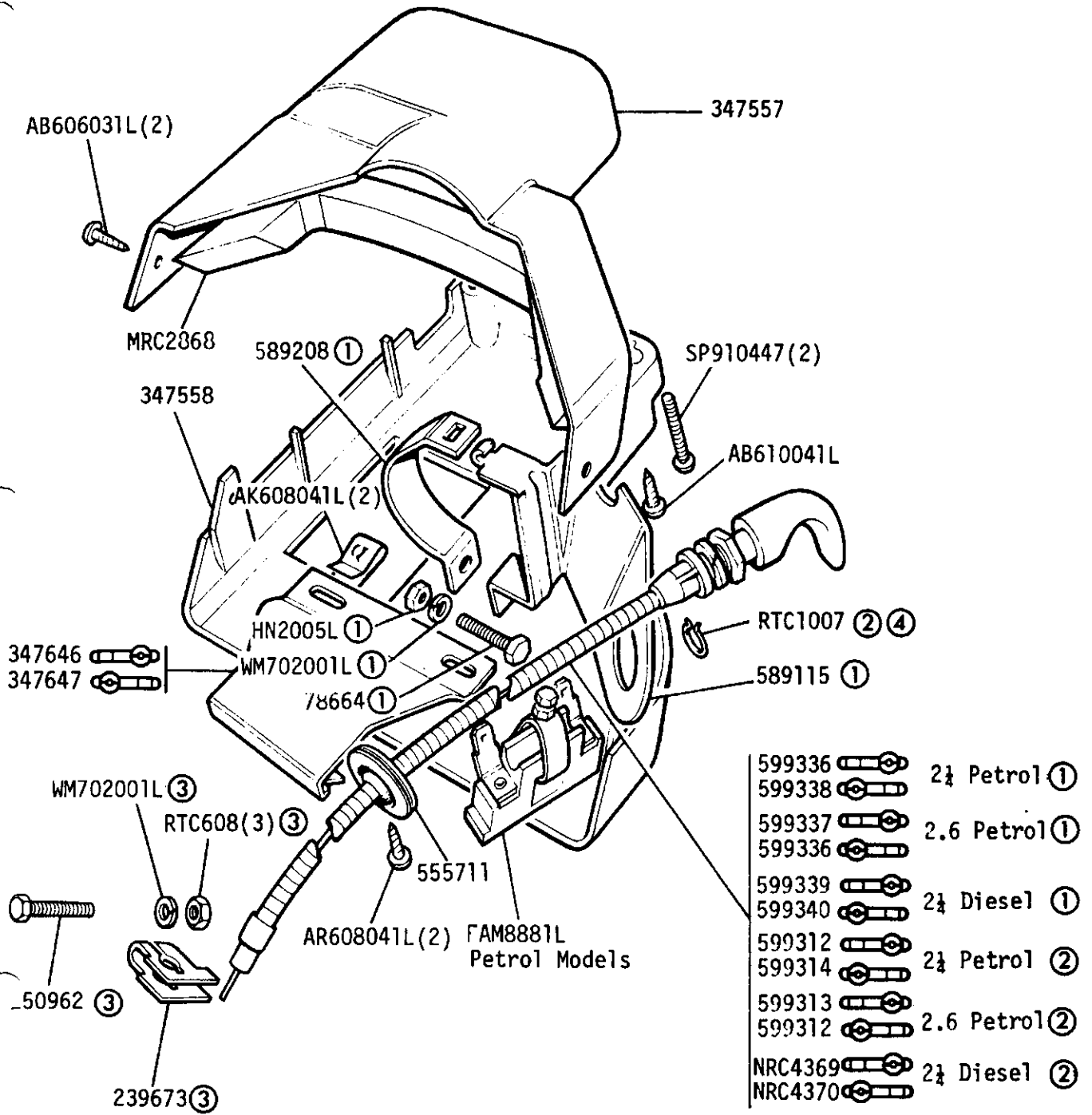

- ① Models without steering column locks
- ② Models with steering column locks
- ③ 2½ litre Diesel
- ④ Petrol models

Choke control NRC5069 RH Stg 109 V8
Choke control NRC5070 LH Stg 109 V8

GROUP H
HEAT SHIELD - 2½ Litre Petrol

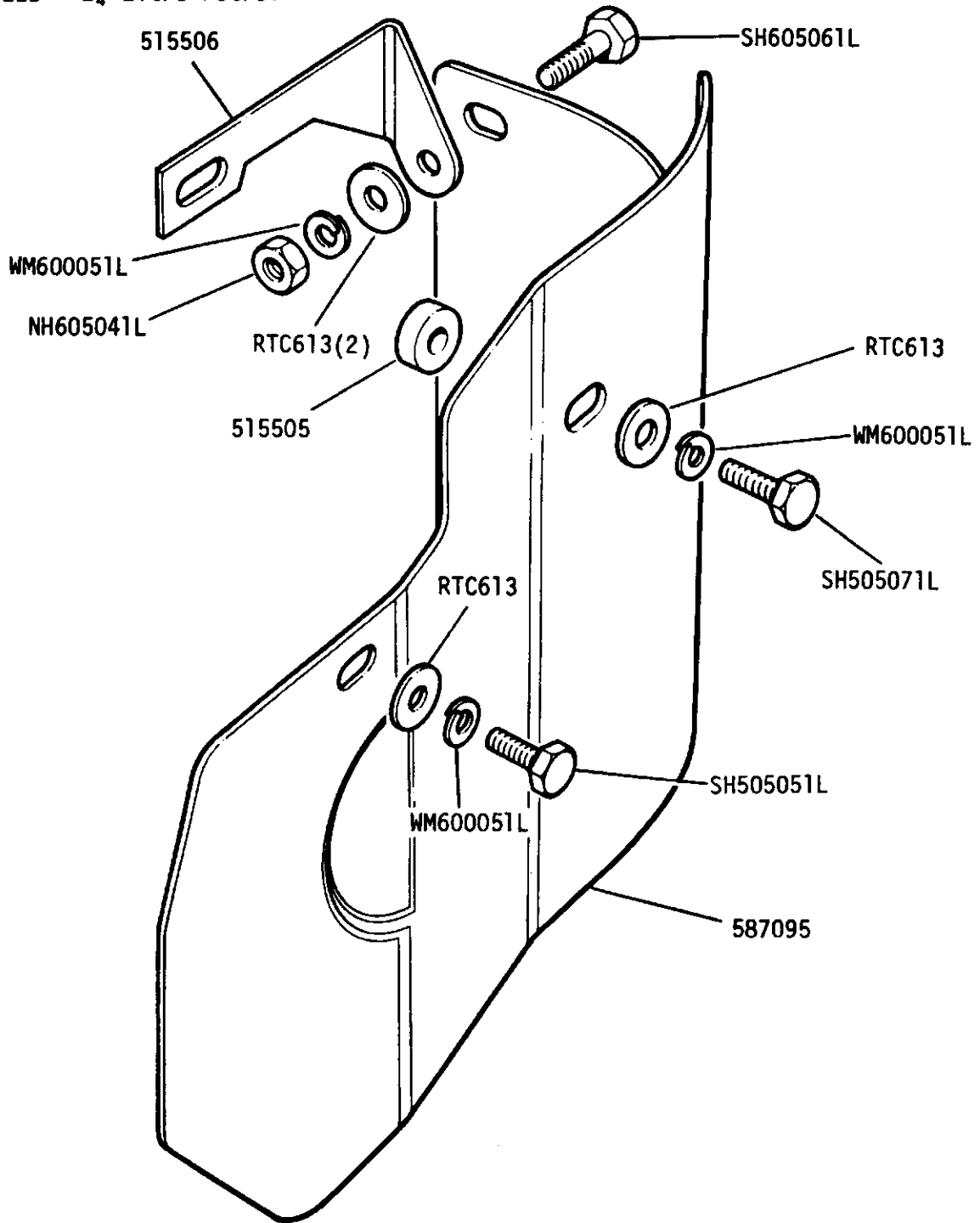

GROUP H
EXHAUST SYSTEM - Front Exhaust Pipe 2½ Litre Petrol and Diesel

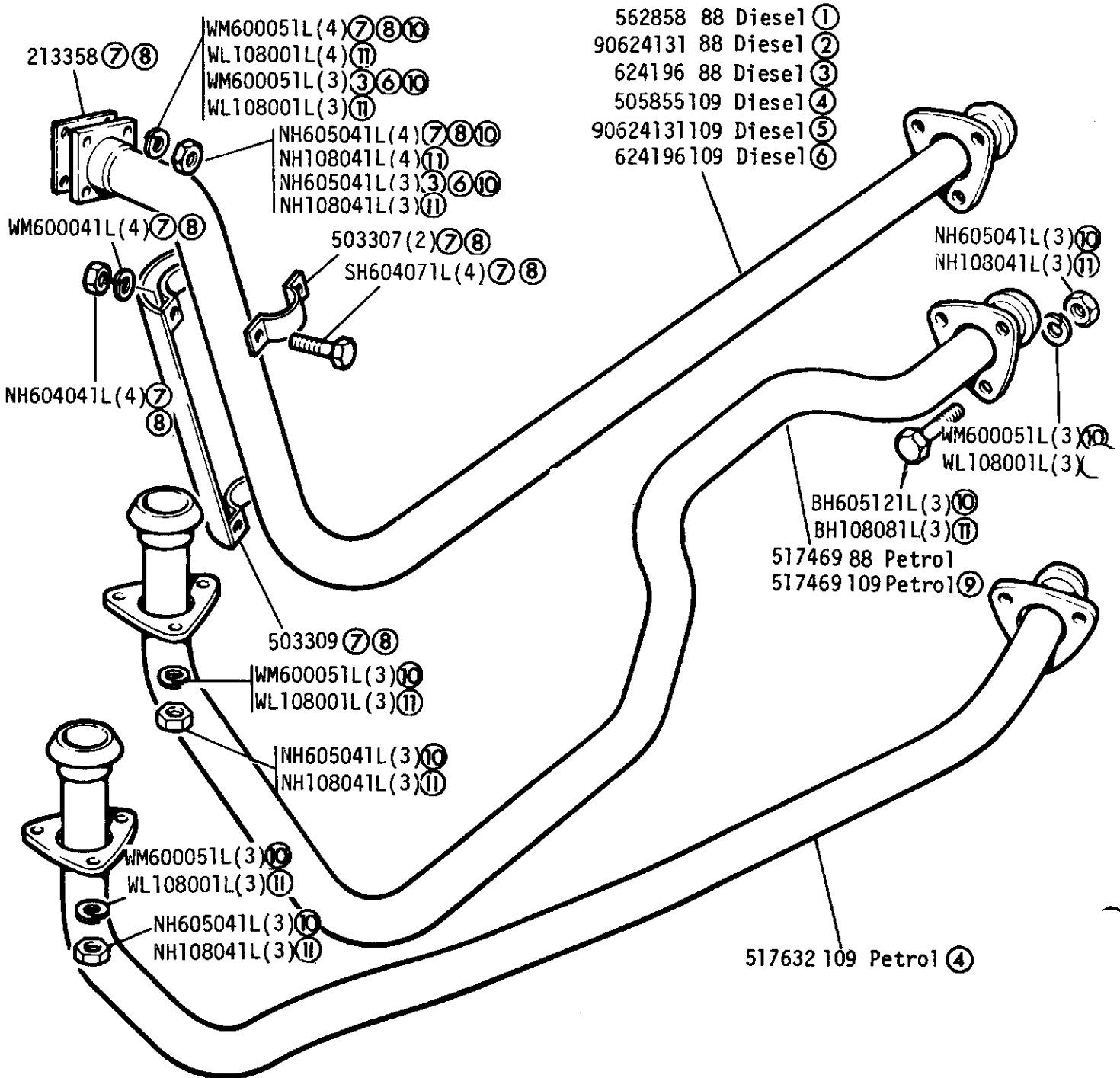

- | | |
|---|--|
| ① Vehicle suffix 'A' up to September 1973 | ⑧ 109" Diesel up to vehicle suffix 'C' inclusive |
| ② Vehicle suffix 'A' from October 1973 to July 1974 | ⑨ 109 Petrol from vehicle suffix 'C' onwards |
| ③ From vehicle suffix 'B' onwards | ⑩ UNF |
| ④ Up to vehicle suffix 'B' inclusive | ⑪ METRIC |
| ⑤ Vehicle suffix 'C' only | |
| ⑥ From vehicle suffix 'D' onwards | |
| ⑦ 88" Diesel vehicle suffix 'A' | |

GROUP H
EXHAUST SYSTEM - Intermediate Exhaust Pipe 88in

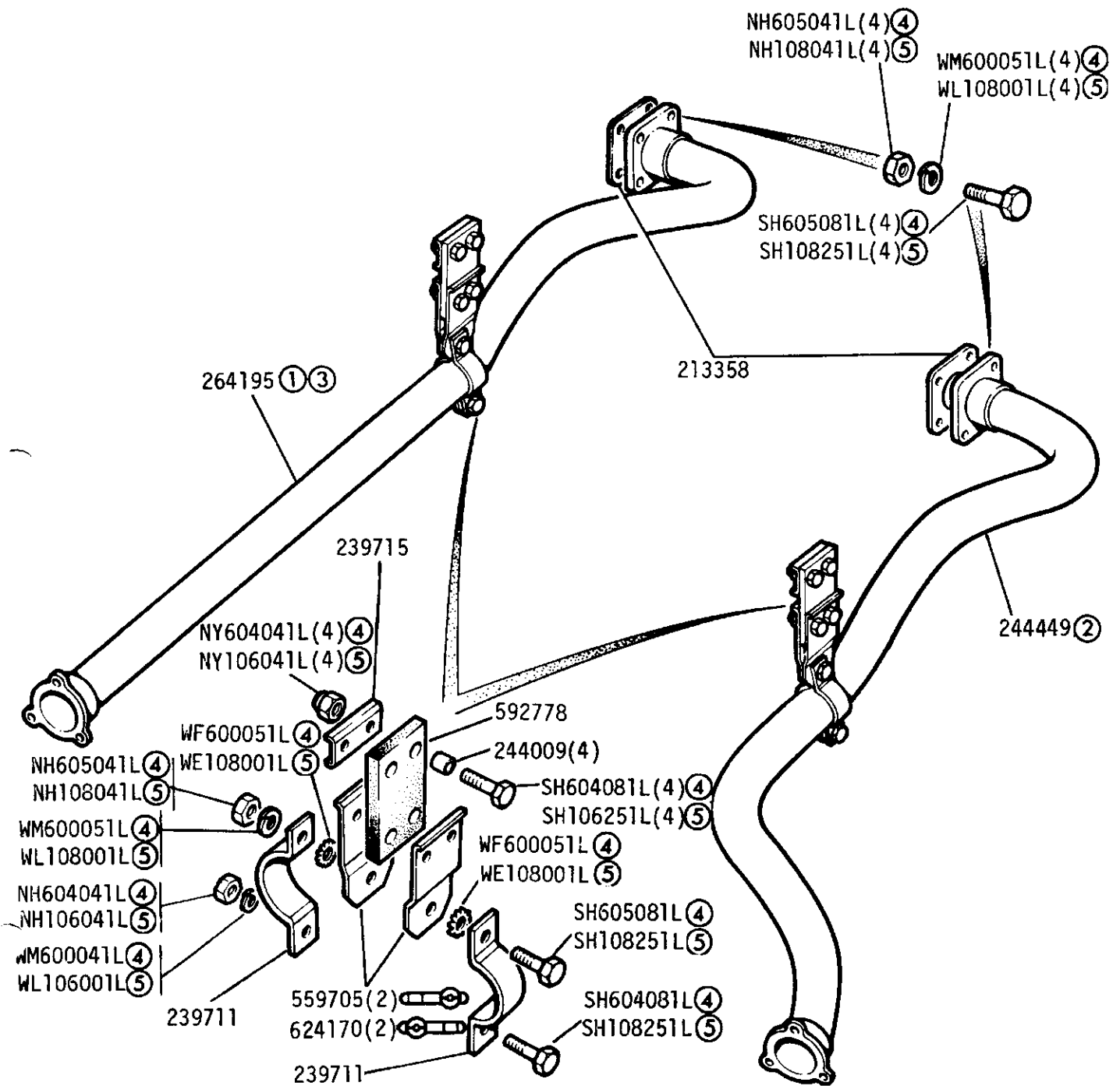

- ① Petrol models
- ② Diesel models up to September 1973
- ③ Diesel models from October 1973 onwards
- ④ UNF
- ⑤ METRIC

GROUP H

EXHAUST SYSTEM - Intermediate Exhaust Pipe 109in 4 cyl - Except Station Wagon up to Vehicle suffix 'B' inclusive

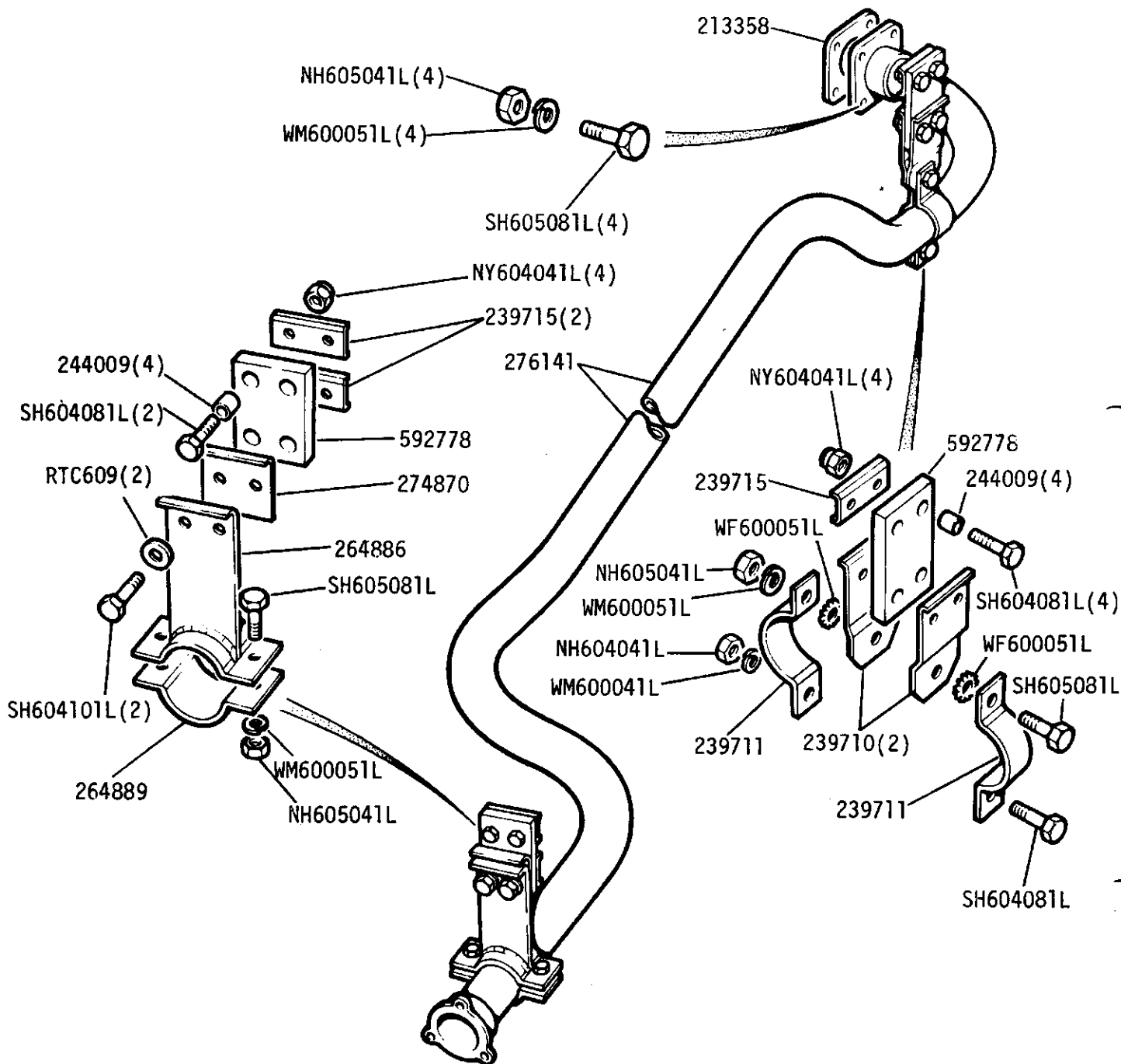

GROUP H
 EXHAUST SYSTEM - Intermediate Exhaust Pipe 109in 4 cyl Station Wagon up to Vehicle
 suffix 'B' inclusive

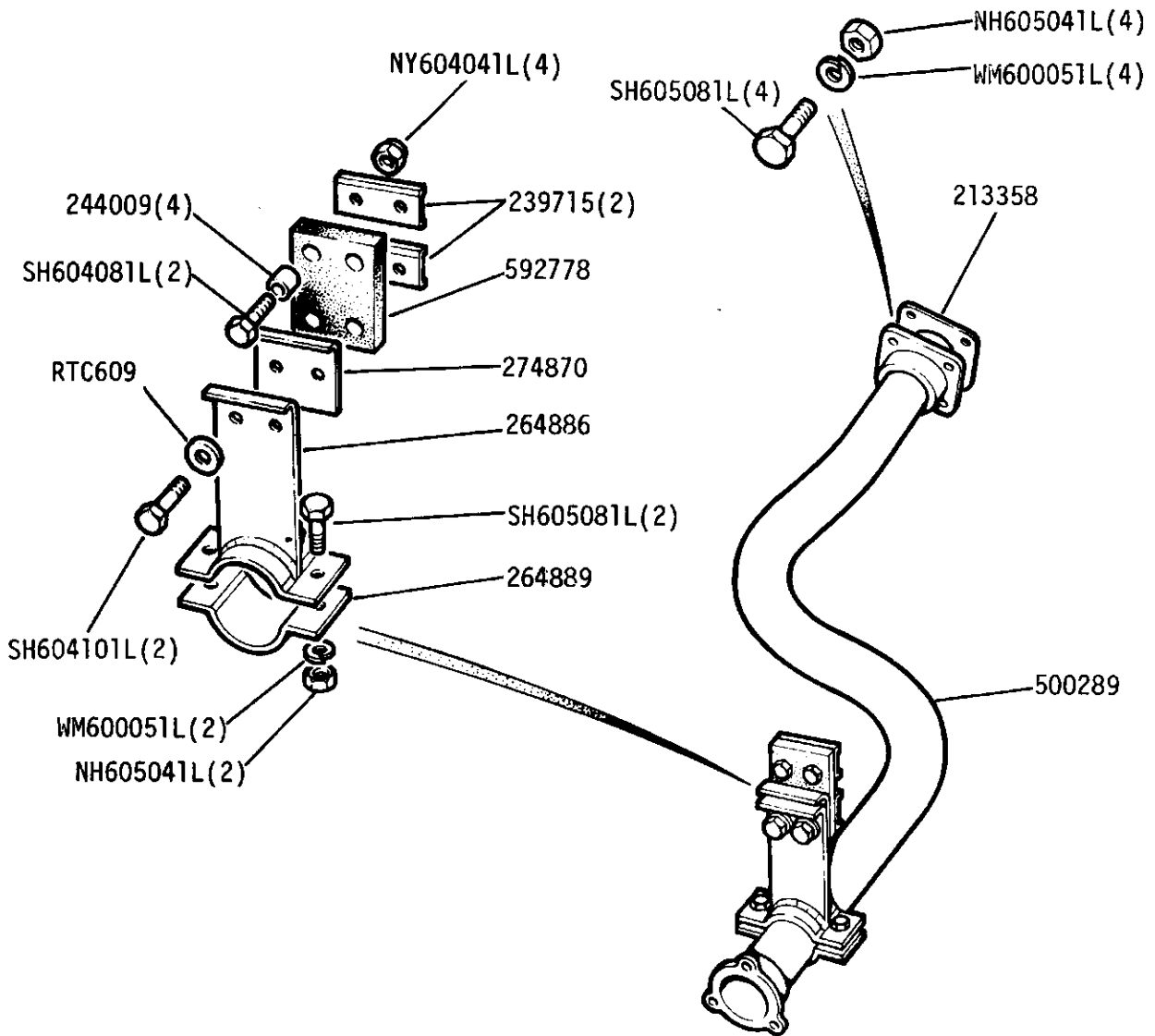

GROUP H

EXHAUST SYSTEM - Intermediate Exhaust Pipe - 109in 4cyl All models from Vehicle suffix 'C' onwards.

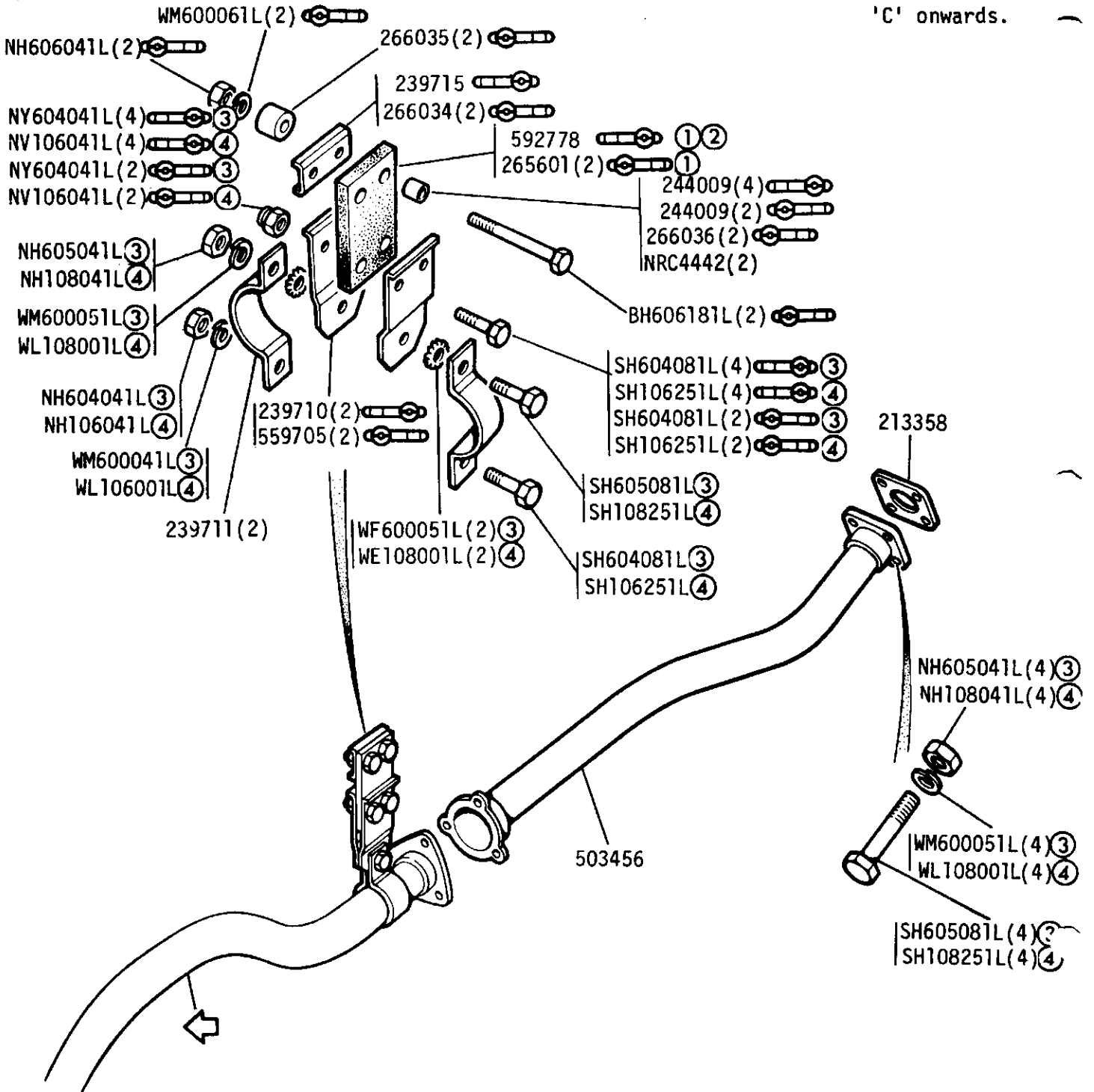

- ① Upto March 1981
- ② Fitted from April 1981 onwards on RH Stg and LH Stg vehicles
- ③ UNF
- ④ METRIC

GROUP H
 EXHAUST SYSTEM - Silencer and Tail Pipe 88in 

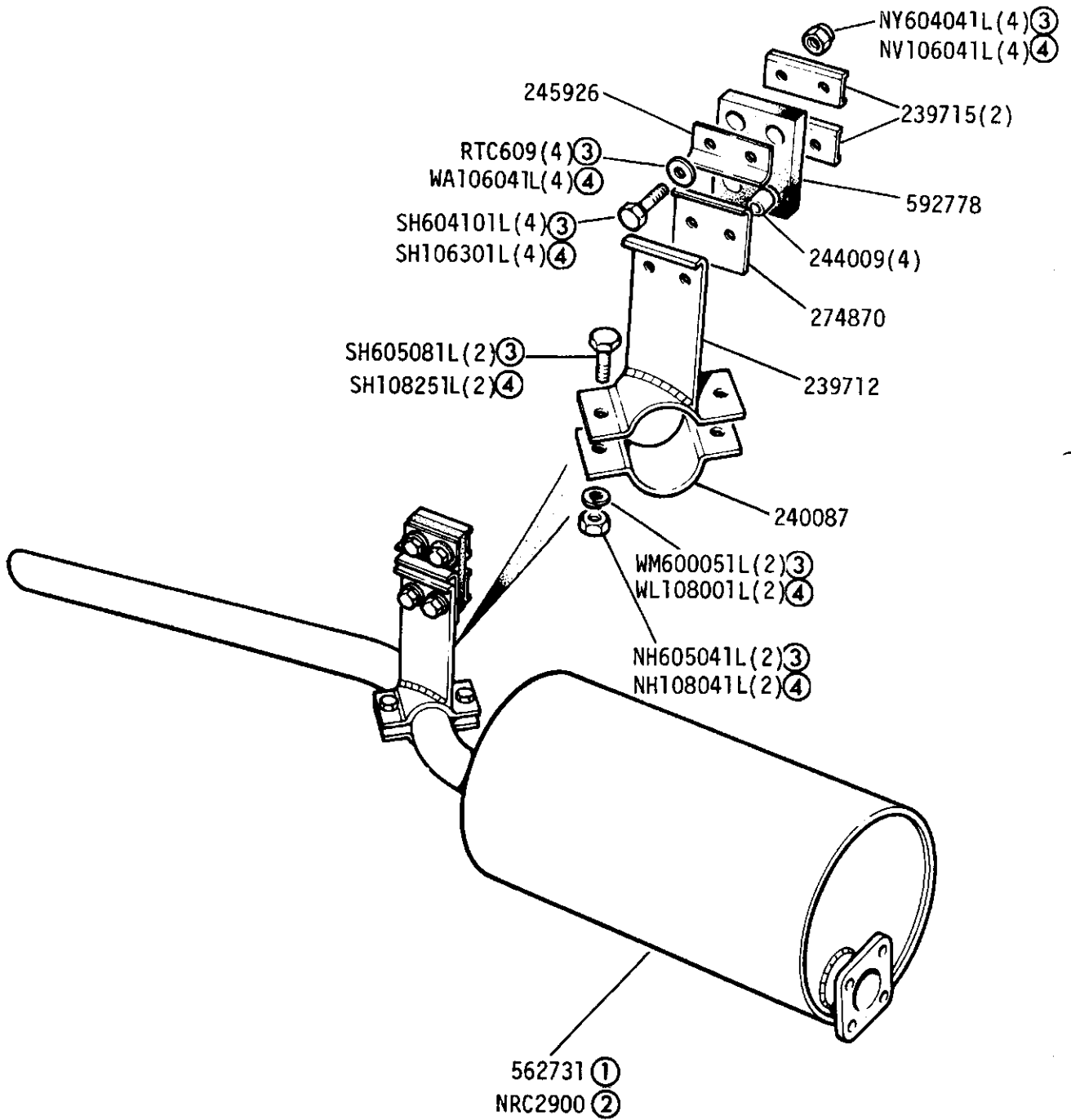

- ① Up to November 1976
- ② From December 1976 onwards
- ③ UNF
- ④ METRIC

GROUP H
 EXHAUST SYSTEM - Silencer and Tail Pipe 88in 

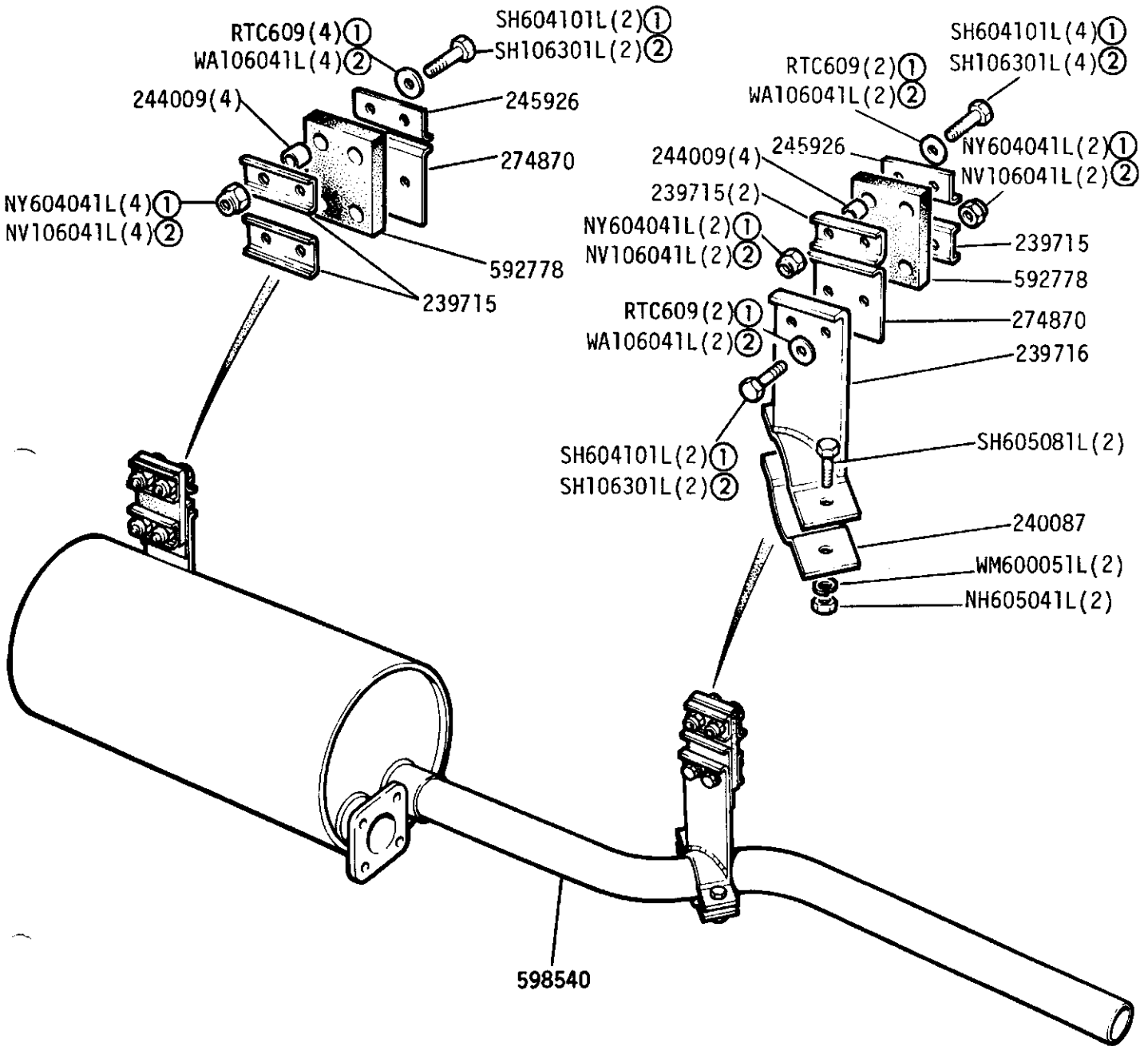

- ① UNF
- ② METRIC

GROUP H

EXHAUST SYSTEM - Silencer and Tail Pipe 109in 4cyl  - Except Station Wagon up to Vehicle suffix 'B' inclusive

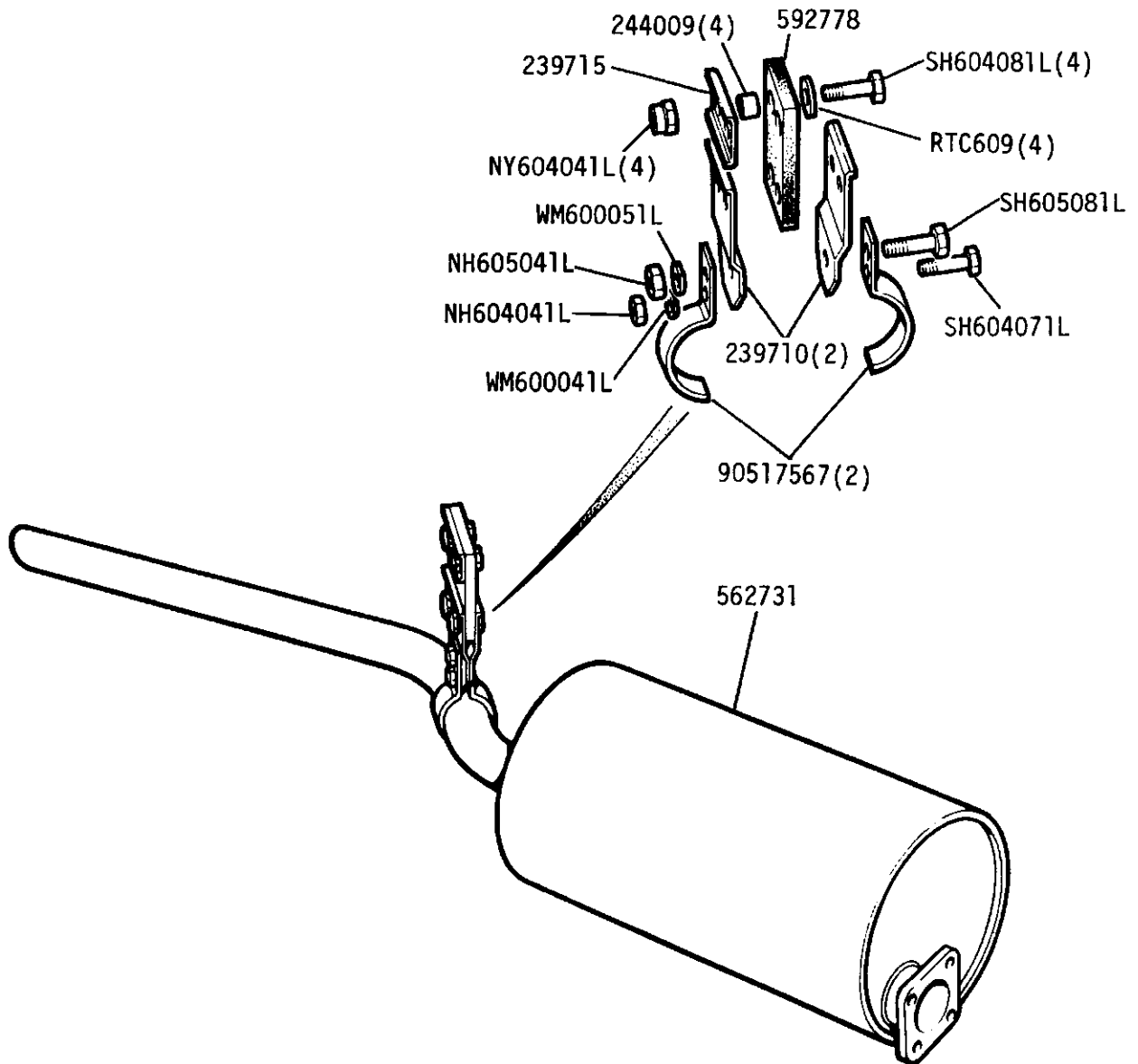

GROUP H

EXHAUST SYSTEM - Silencer and Tail Pipe 109in 4cyl  - Except Station Wagon up to Vehicle suffix 'B' inclusive

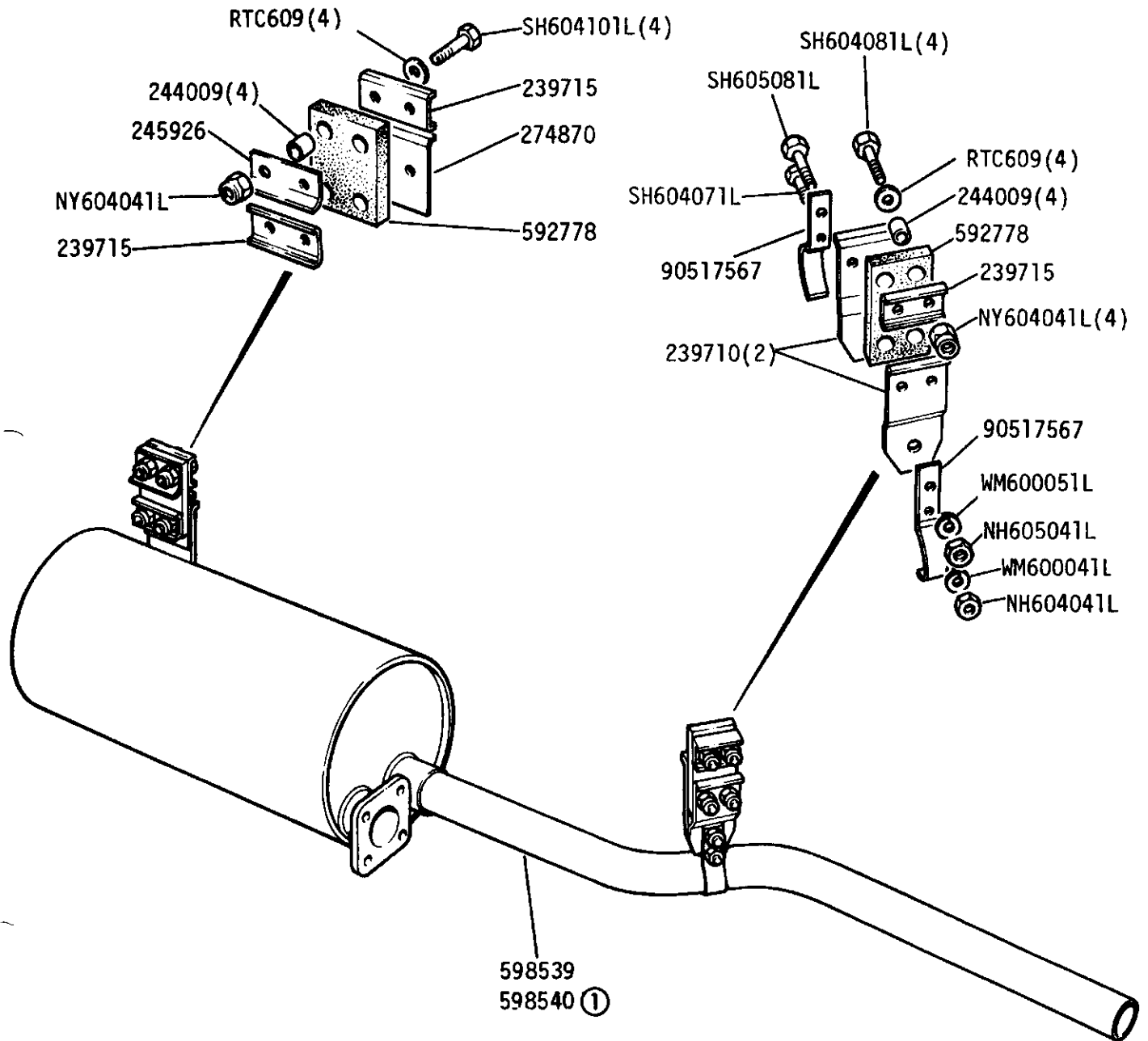

① Angled exhaust silencer for Germany and Switzerland

GROUP H

EXHAUST SYSTEM - Silencer and Tail Pipe 109in 4cyl - Station Wagon up to Vehicle suffix 'B' inclusive

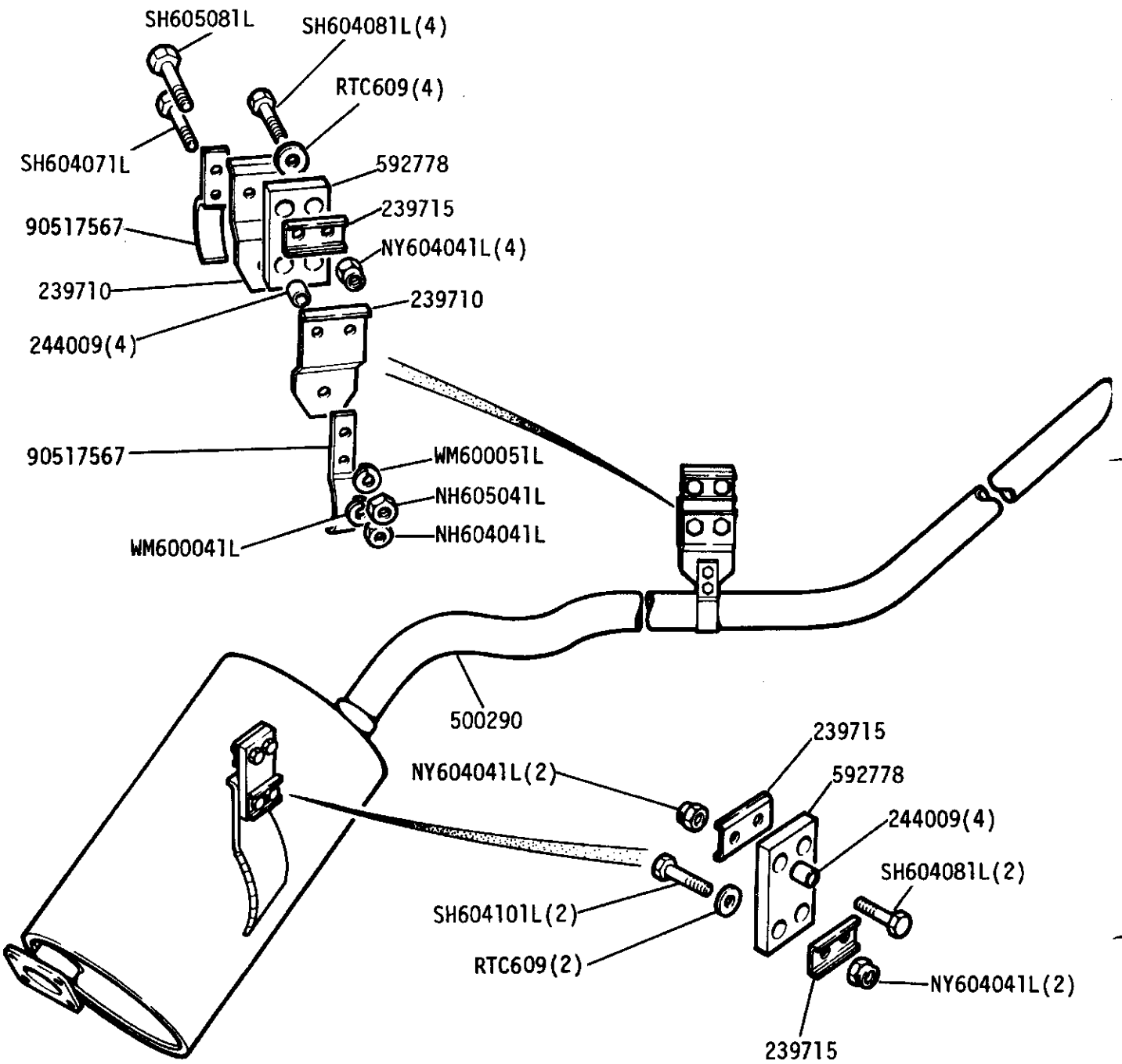

GROUP H

EXHAUST SYSTEM - Silencer and Tail Pipe 109ir 4cyl - All models from Vehicle suffix 'C' onwards

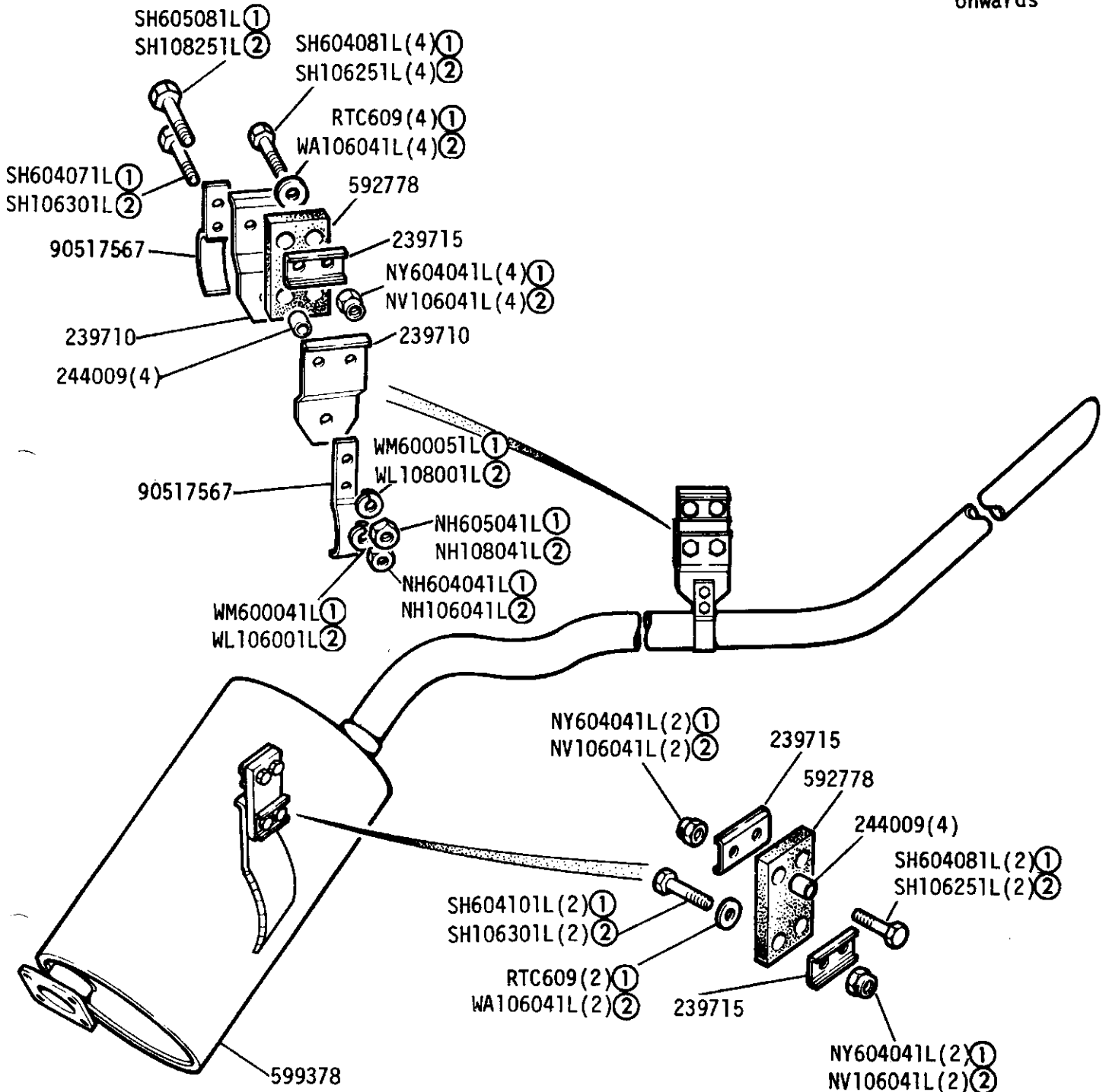

- ① UNF
- ② METRIC

GROUP H
EXHAUST SYSTEM - Manifold Heat Shield 2.6 Litre Petrol (Detoxed and Non-Detoxed)

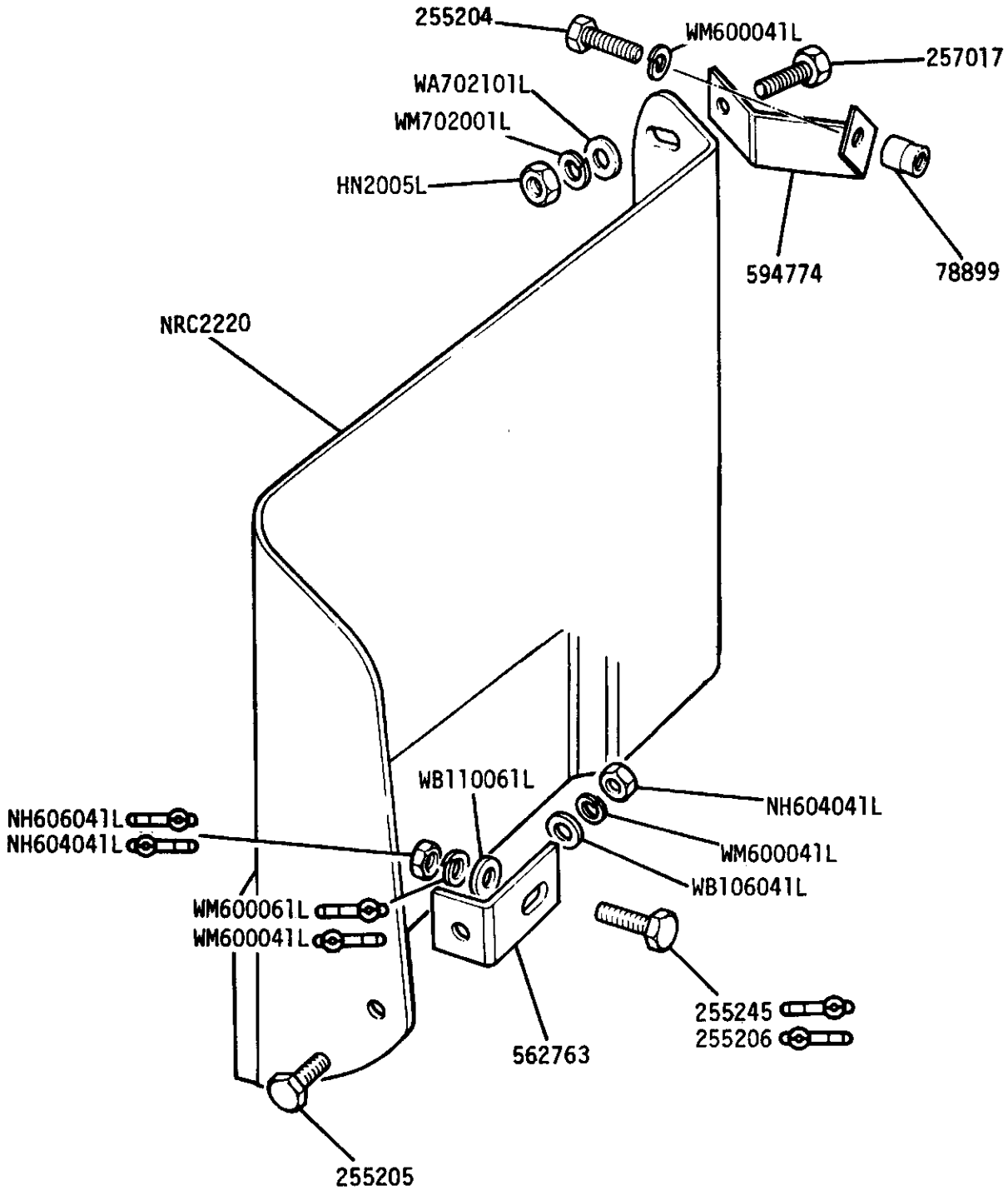

GROUP H

EXHAUST SYSTEM - Front and Intermediate Exhaust Pipe - 2.6 Litre Petrol

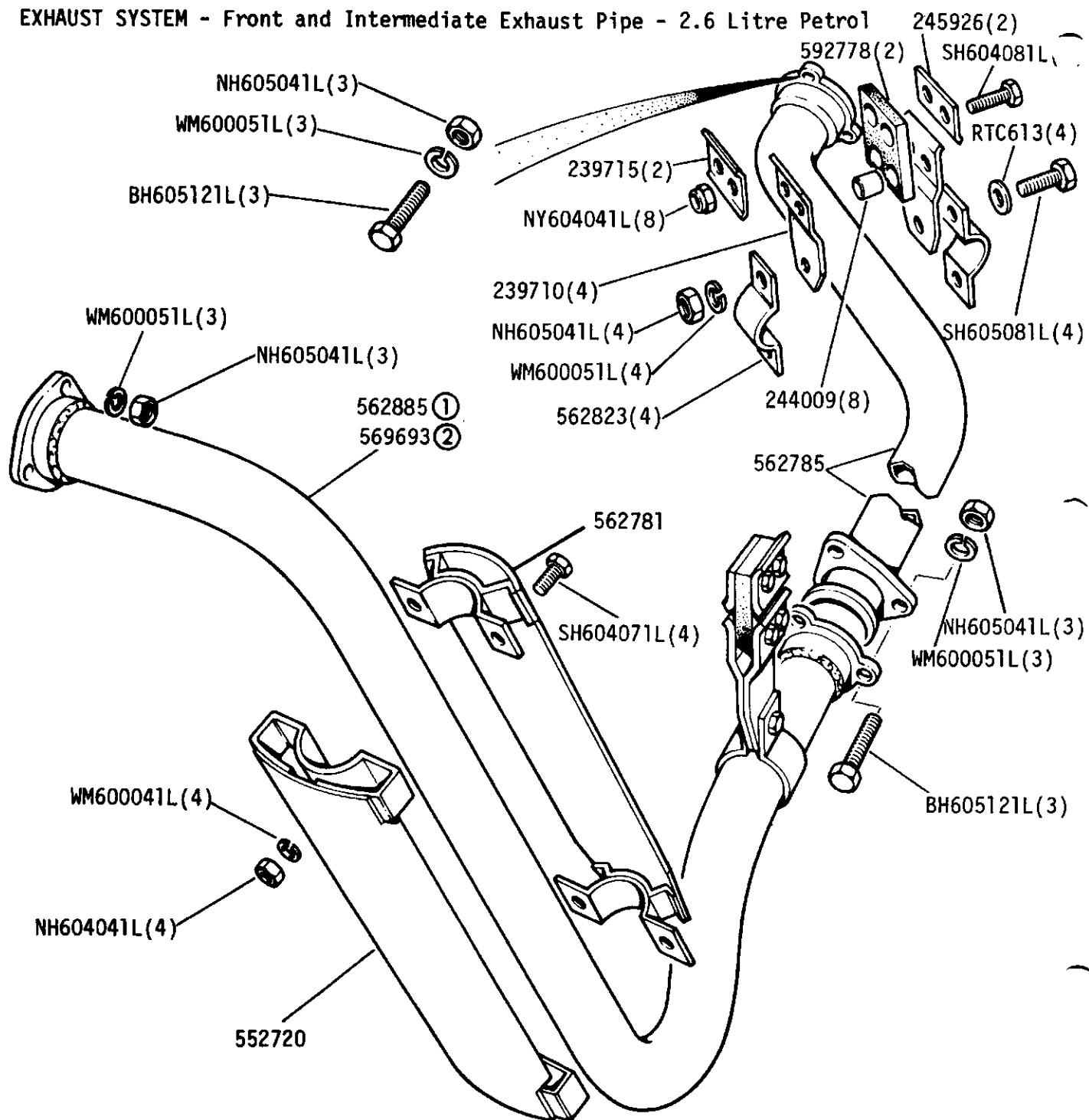

① Except 1 Ton

② 109 1 Ton

GROUP H
 EXHAUST SYSTEM - Silencer and Tail Pipe - 2.6 Litre Petrol

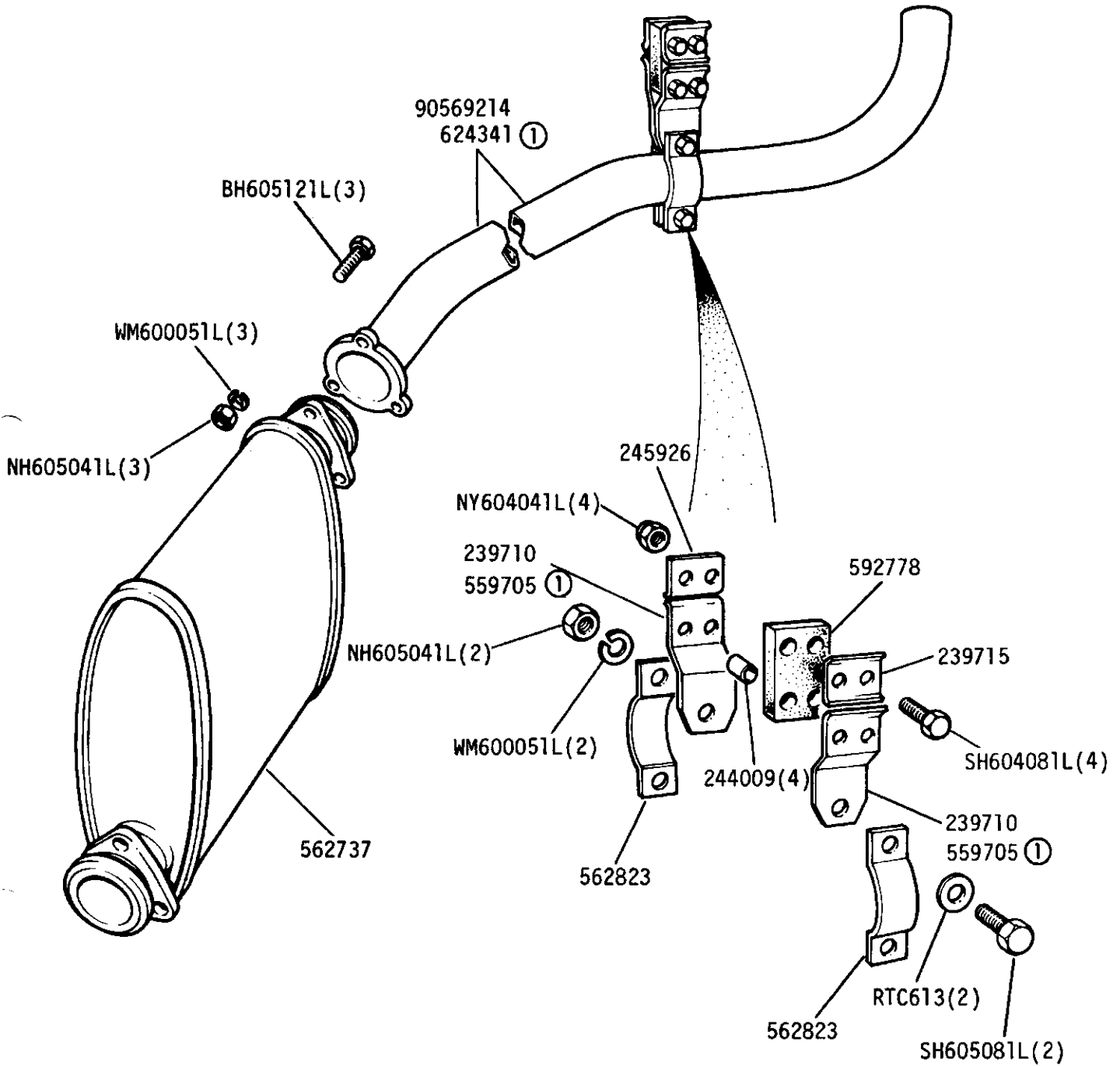

① Belgium

GROUP H
EXHAUST SYSTEM - Downpipes, 109V8

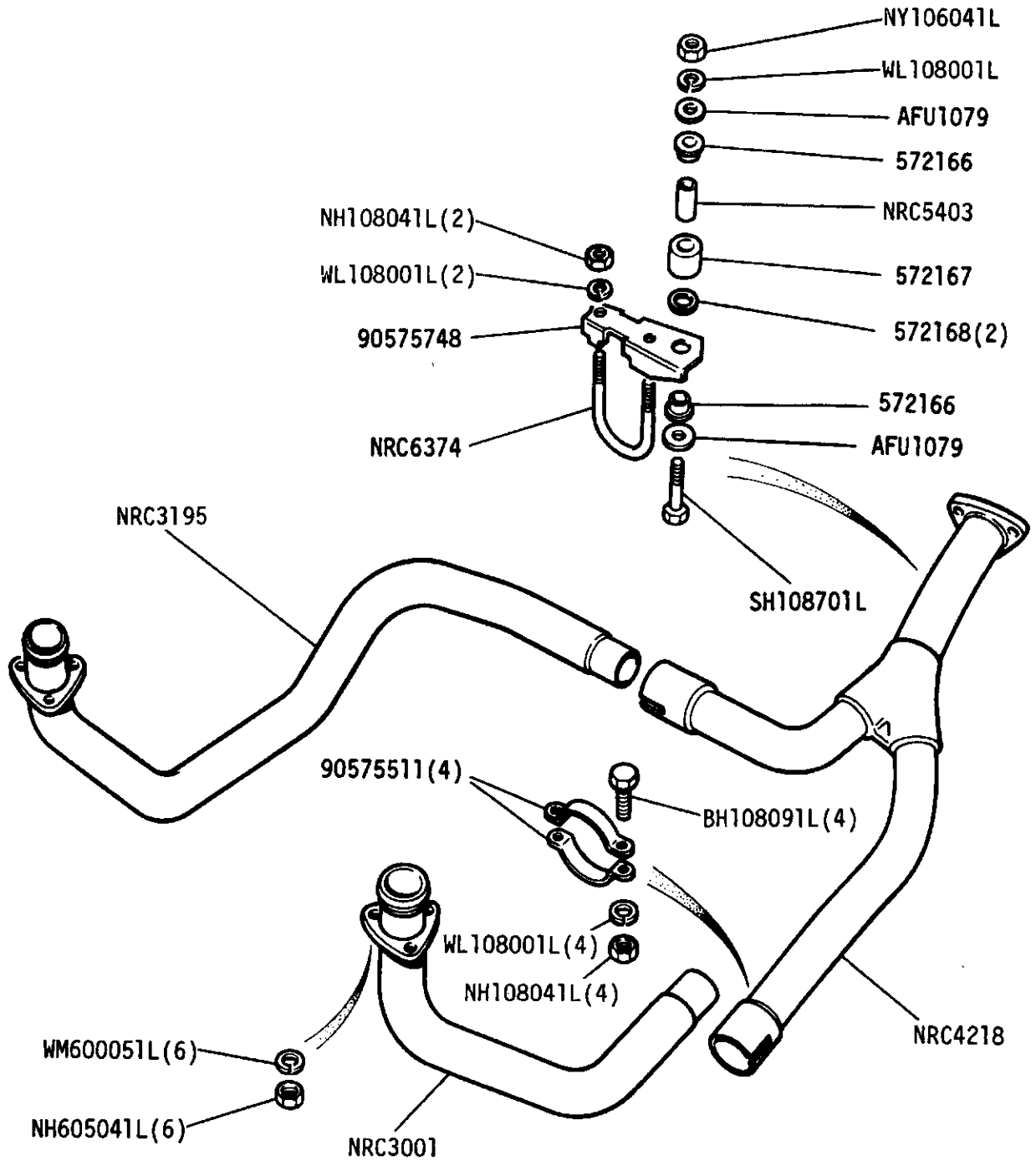

GROUP H
EXHAUST SYSTEM - Intermediate and rear silencers, 109V8

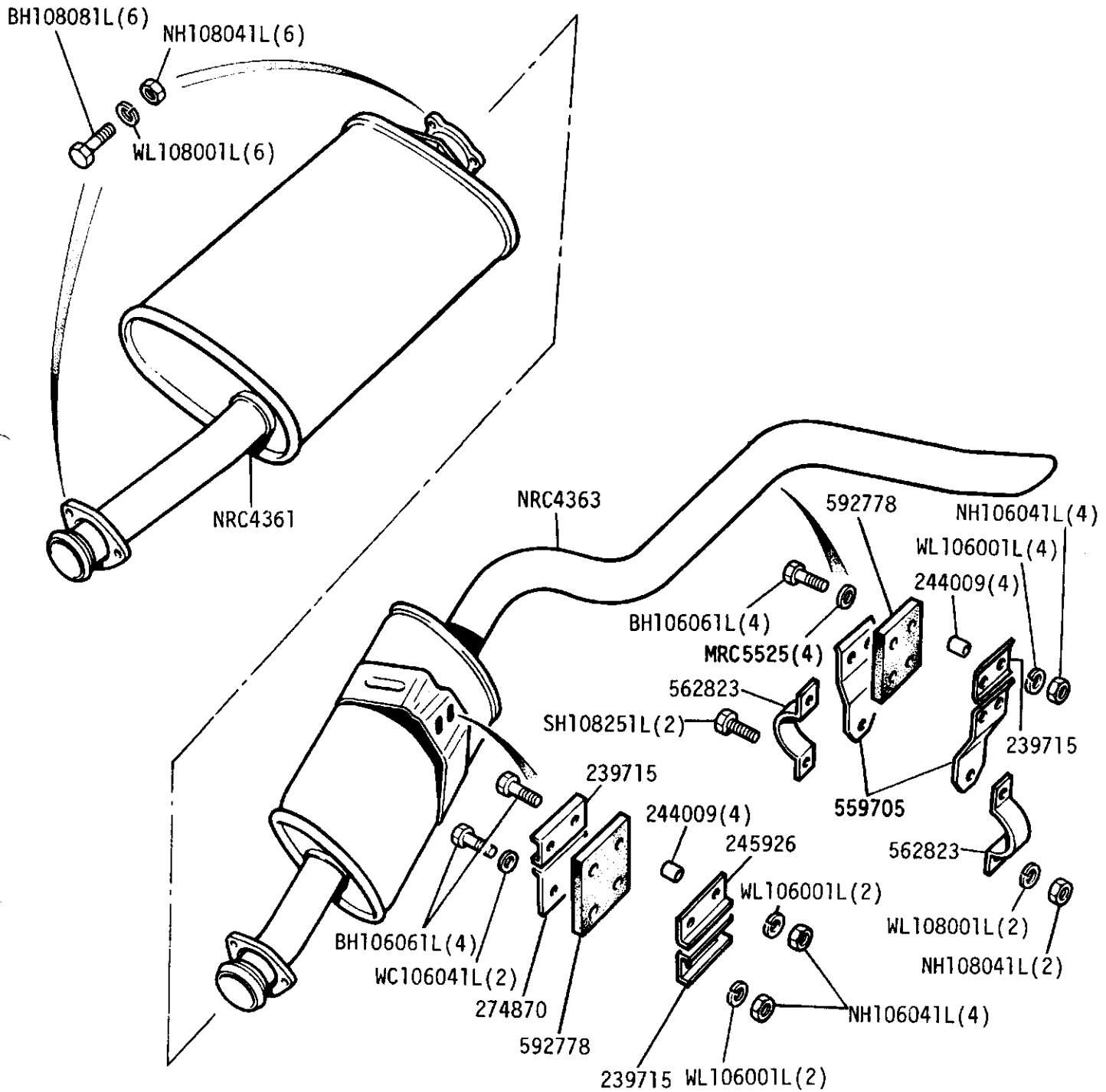

GROUP J

COOLING SYSTEM - Radiator and Hoses

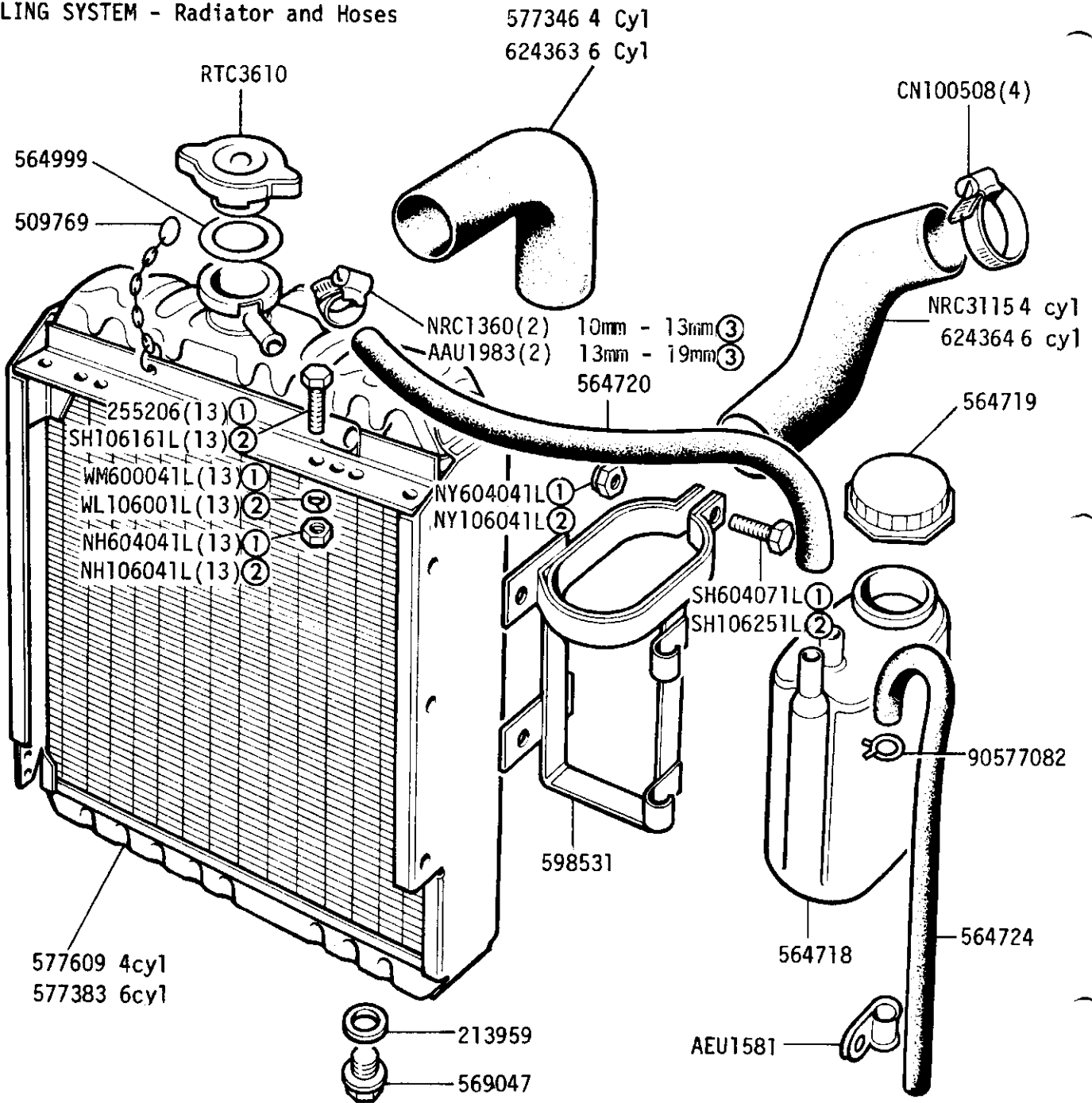

- ① UNF
- ② METRIC
- ③ Alternatives - Check Before Ordering

GROUP J
 COOLING SYSTEM - Radiator Cowl and Shroud

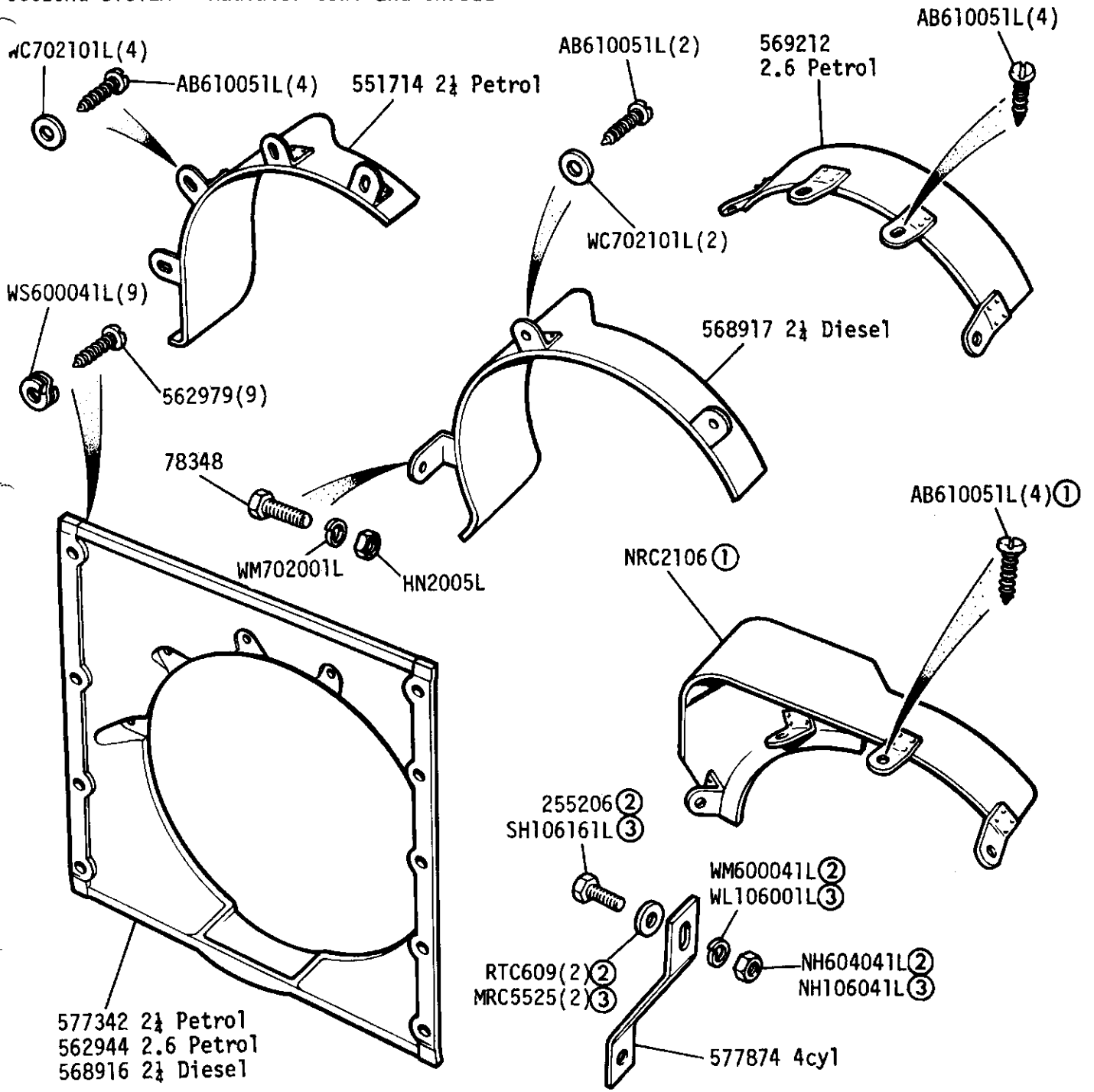

- ① 2.6 Petrol when Detoxed Engine is fitted
- ② UNF
- ③ METRIC

GROUP J
COOLING SYSTEM - Radiator and Fan Cowl - 109V8

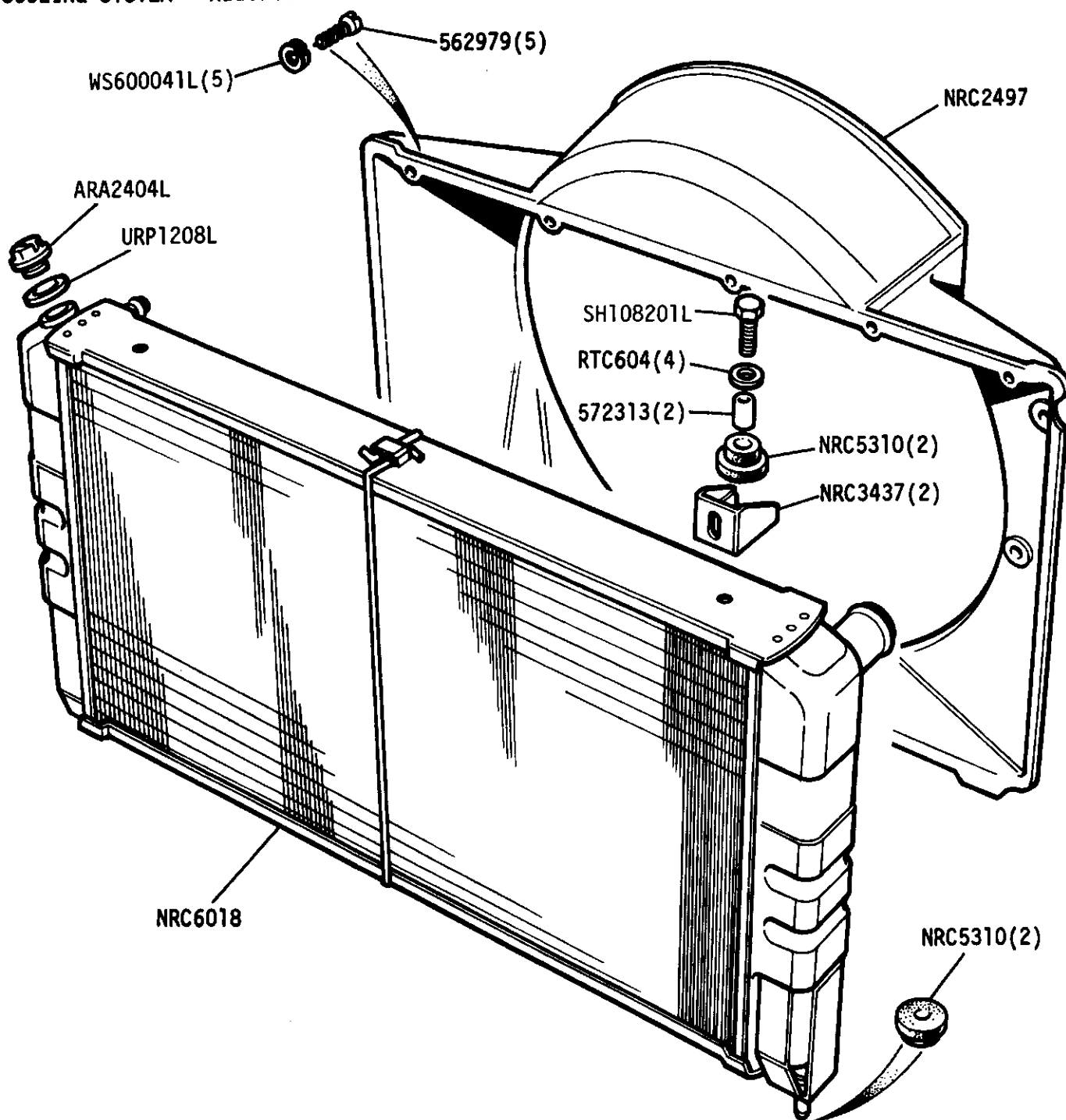

GROUP J
 COOLING SYSTEM - Radiator Hoses - 109V8

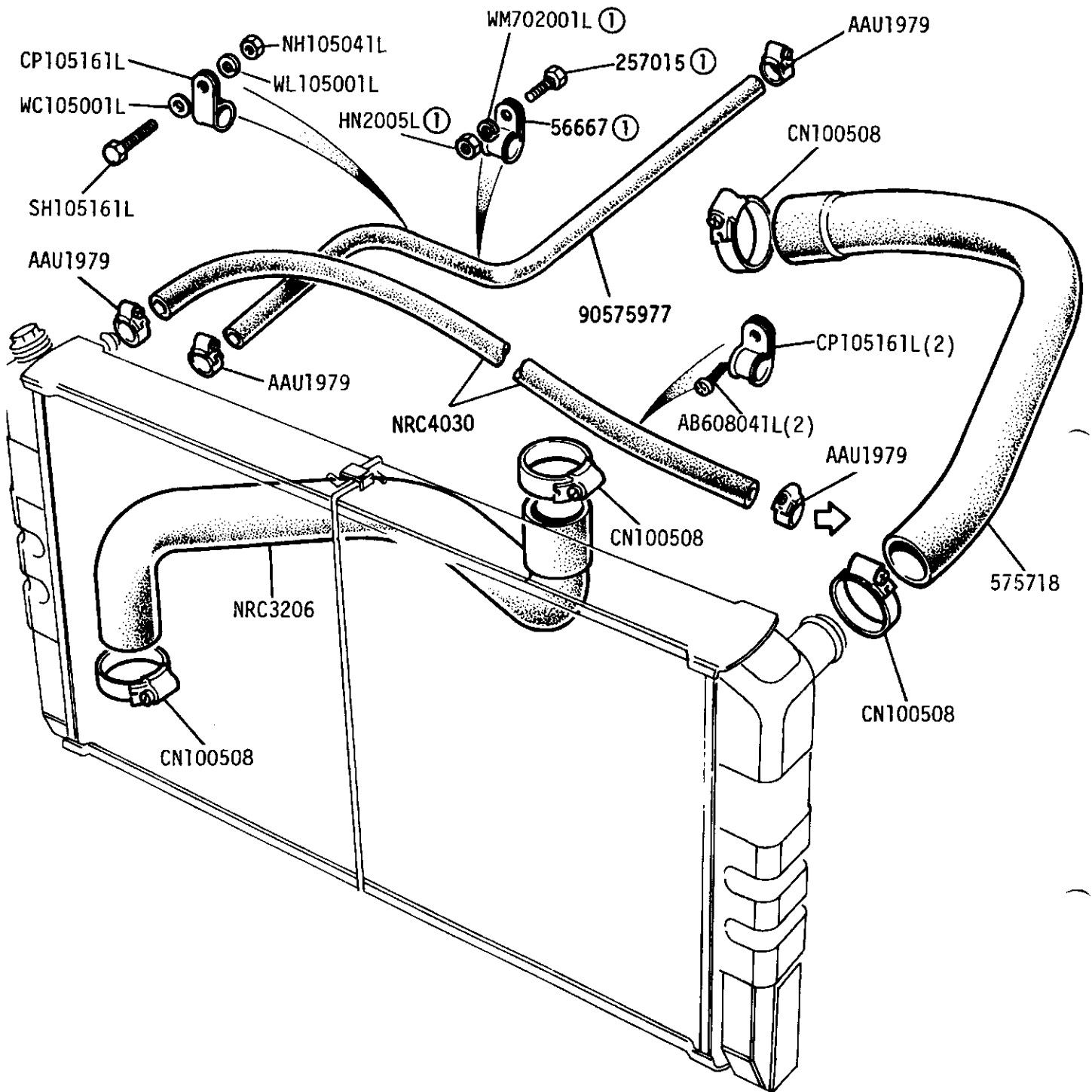

① Detoxed Engine

GROUP J
COLING SYSTEM - Expansion Tank - 109V8

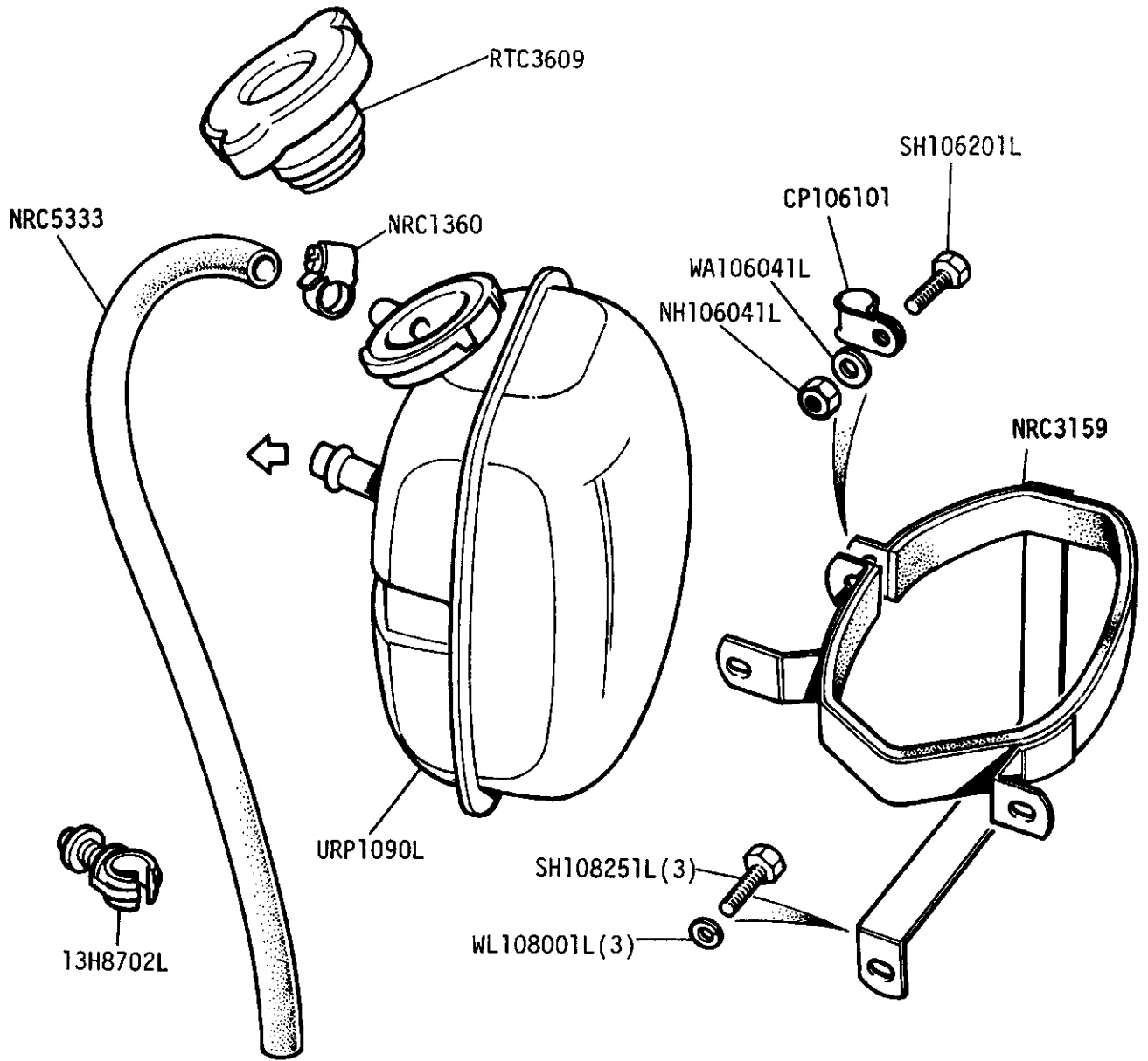

GROUP K

ENGINE - Distributor and High Tension Leads. 2½ Litre Petrol up to Engine Suffix C' inclusive

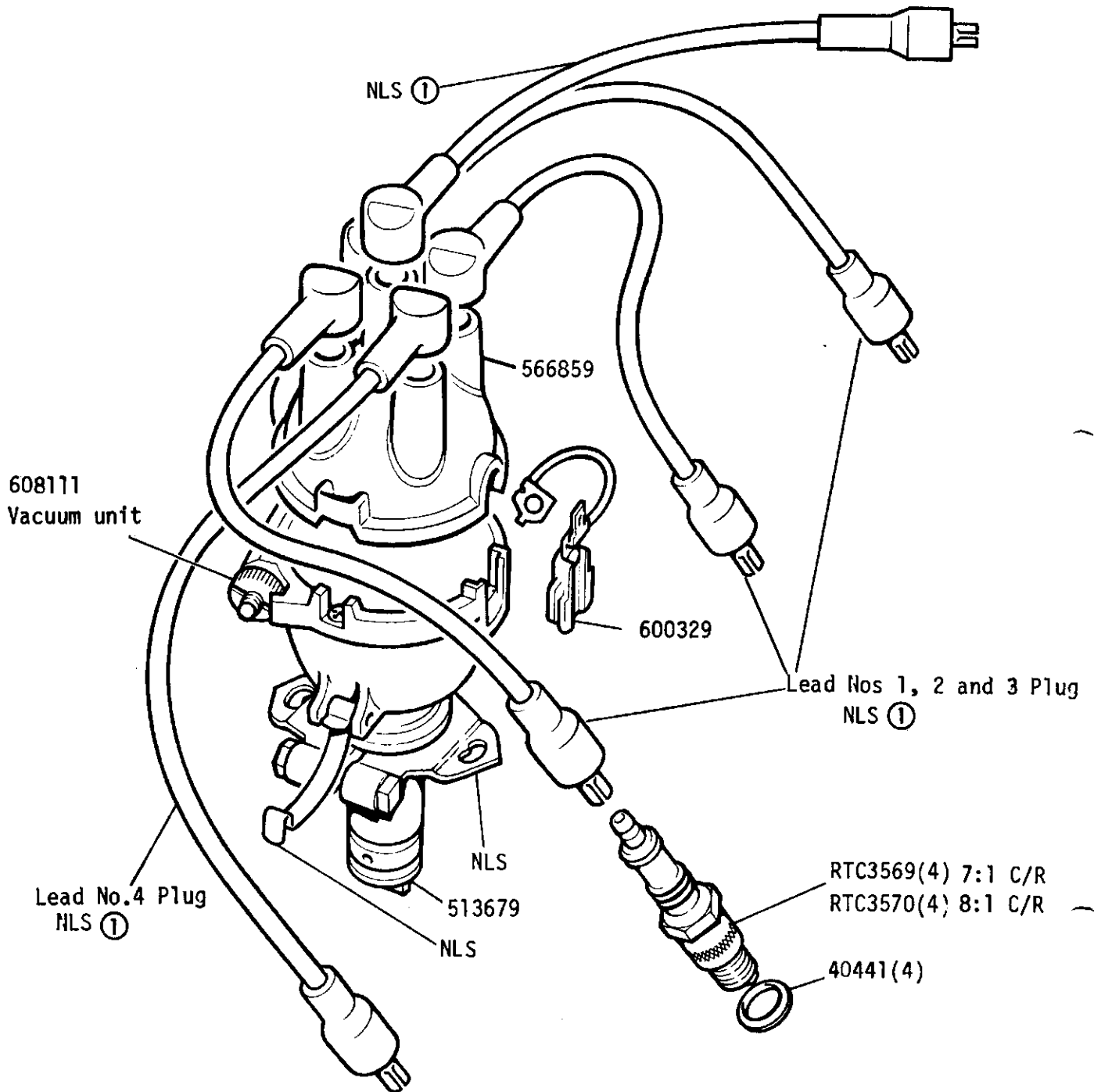

See adjacent frame for distributor components

Distributor complete see frame 2E 03

Sundry parts kit NLS

① Ignition lead set ERC3256

GROUP K

ENGINE - Distributor Components 2½ Litre Petrol up to Engine Suffix 'C' inclusive

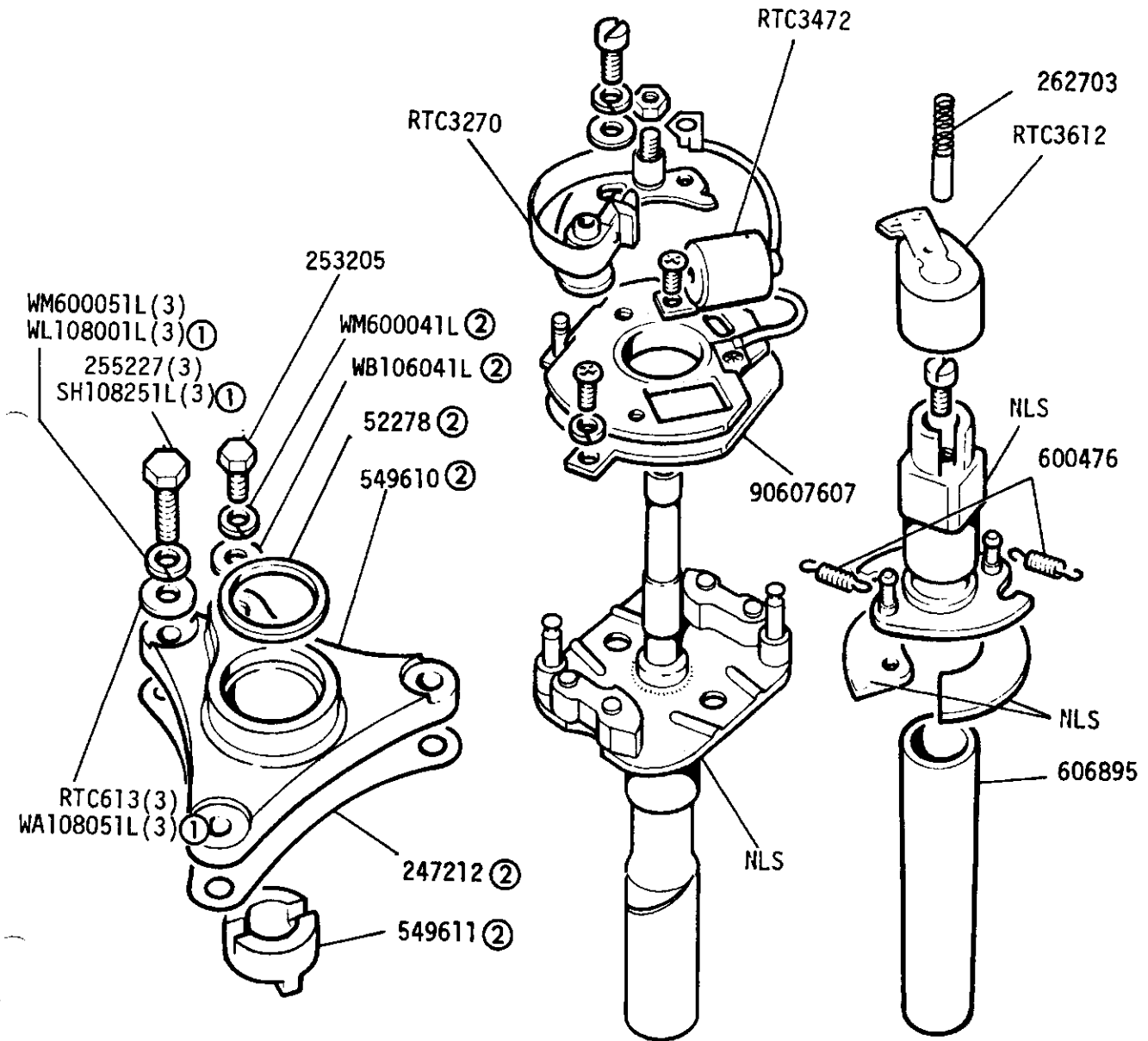

See adjacent frame for distributor components and external components

Sundry Parts Kit NLS

- ① From engine numbers 36123672B, 36407286B
- ② Also fitted from engine suffix D onwards

GROUP K

ENGINE - Distributor and high tension leads from engine suffix 'D' onwards-2½ litre petro

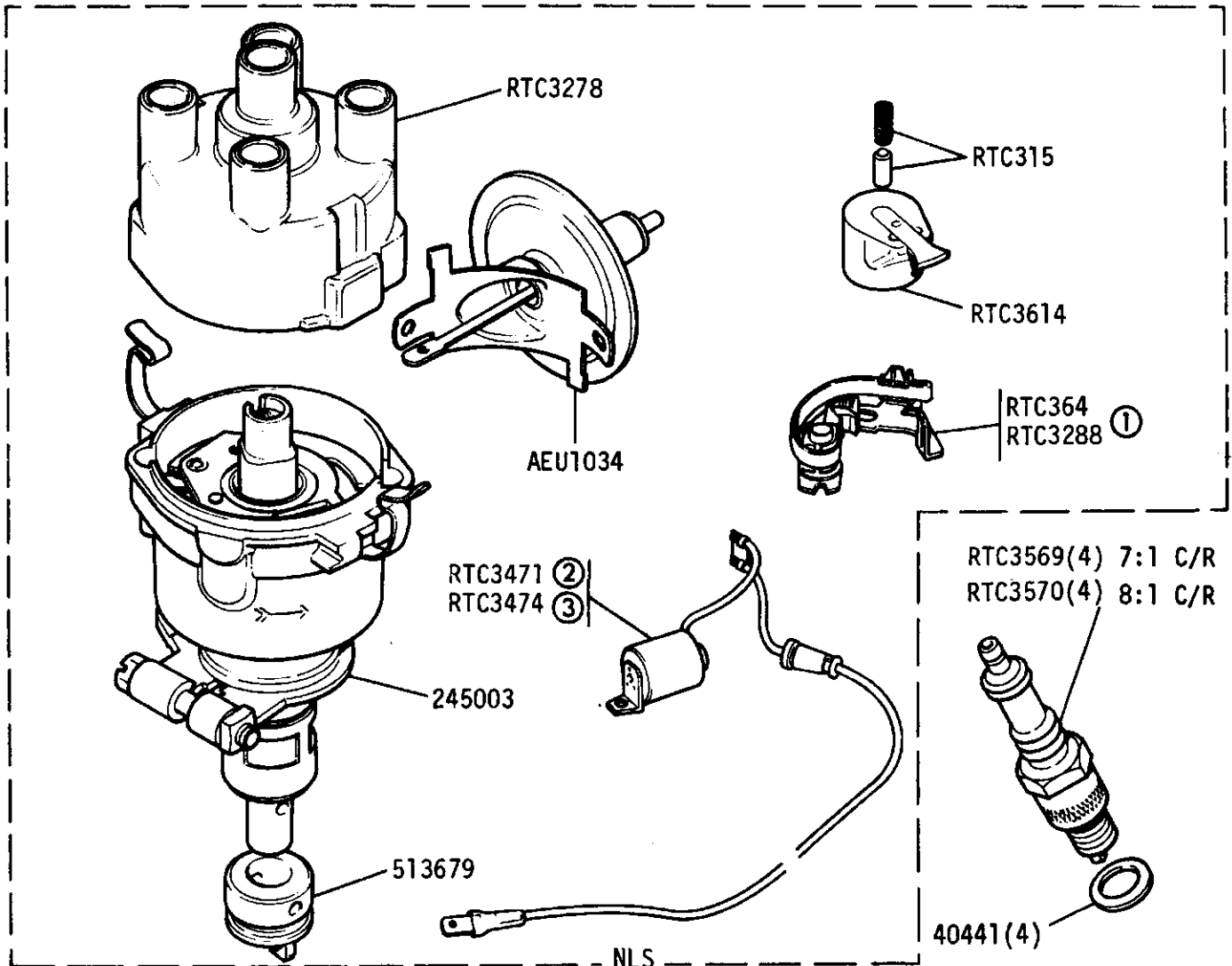
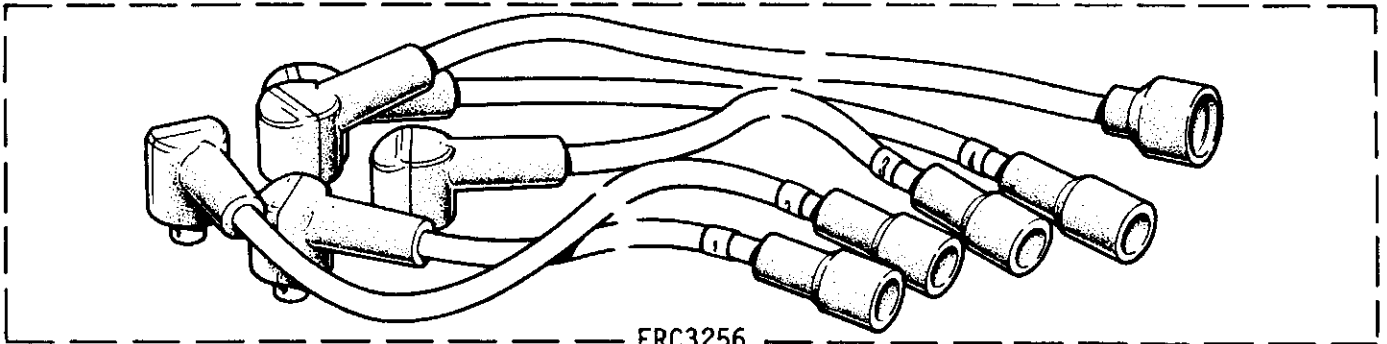

① Alternatives

- ② Long lead length 6 7/8" | Alternatives
- ③ Long lead length 17 7/8" | Check before ordering

For complete distributor use RTC3875

GROUP K

ENGINE - Distributor and high tension leads 2½ litre petrol.

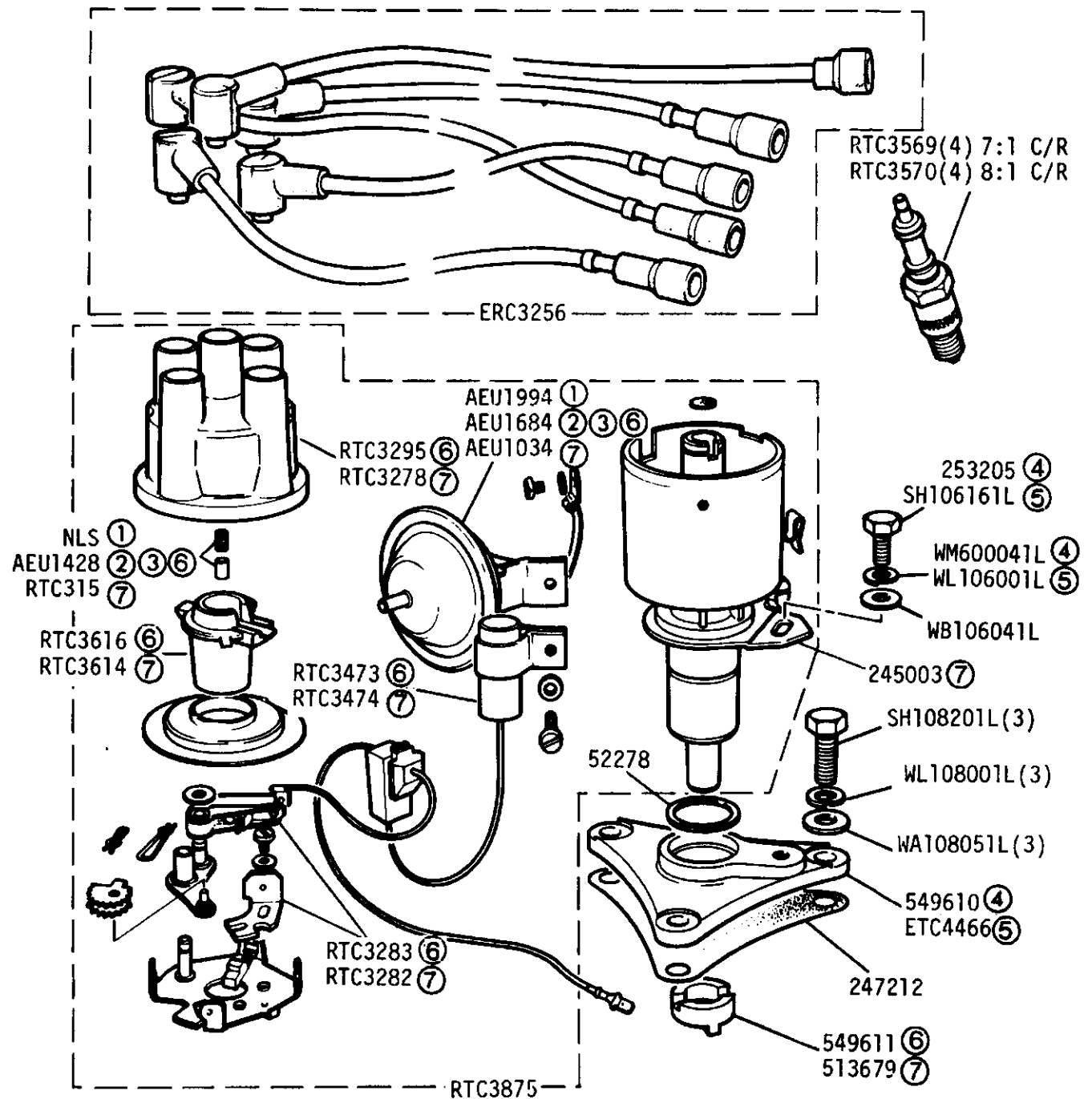

- ① For ECE15-03 European detoxed vehicles up to engine number 36116816A.
- ② For ECE15-03 European detoxed vehicles from engine number 36116817A.
- ③ For use on all other vehicles.
- ④ Engine prefix 901 and 904 and engines prefix 361 and 364 suffix A and B only.
- ⑤ Engines prefix 361 and 364 suffix C onward.
- ⑥ For use on Ducellier distributors.
- ⑦ For use on Lucas distributors.

GROUP K

ENGINE - Distributor and Heat Shield 2.6 Litre Petrol
Up to Engine Suffix 'B' inclusive

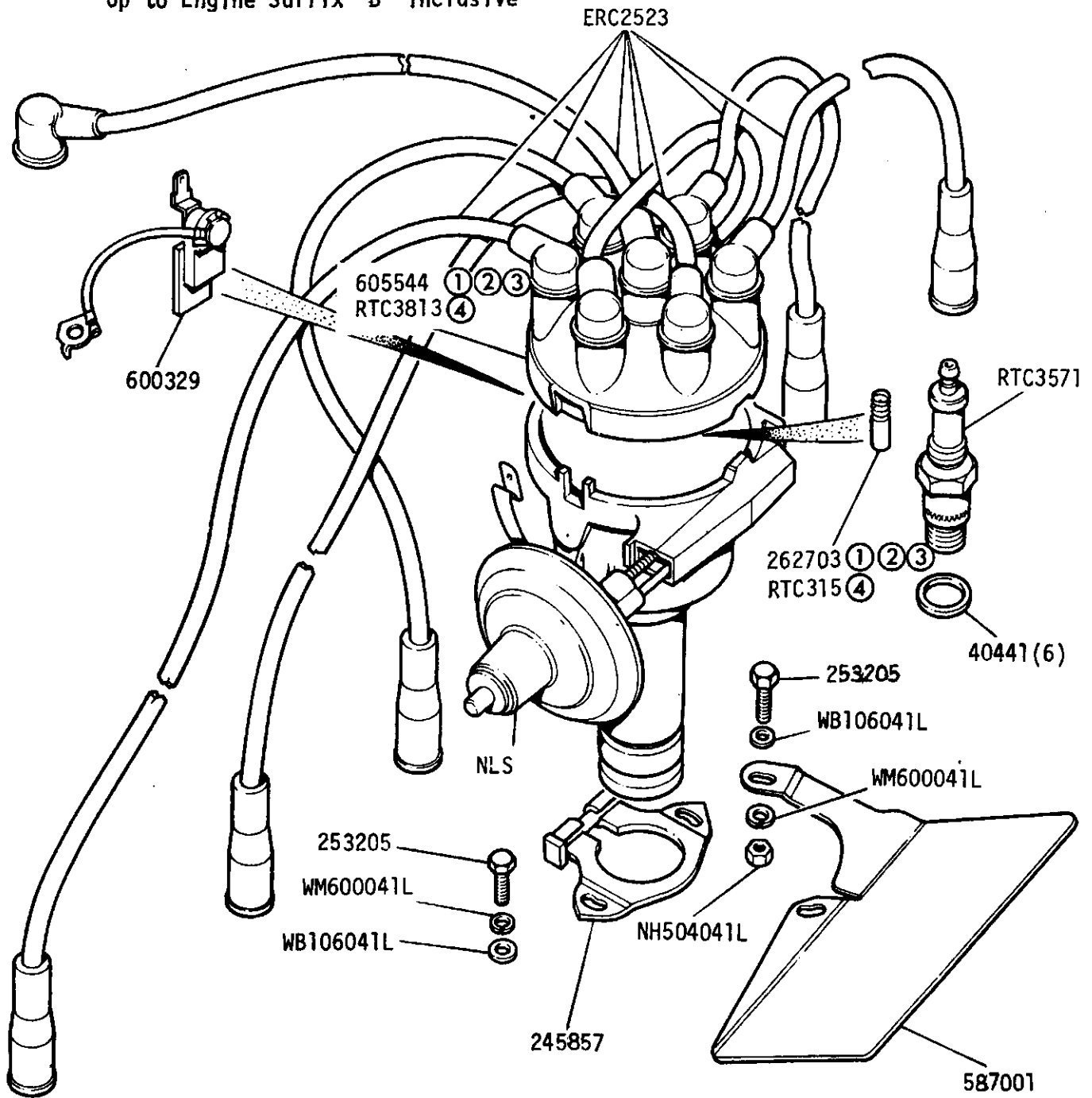

Distributor Complete AEU1124

Sundry Parts Kit NLS

- ① Use with Distributor 568729 Lucas 41227)
- ② Use with Distributor 597735 Lucas 41498)
- ③ Use with Distributor ERC545 Lucas 41585)
- ④ Use with Distributor AEU1124 Lucas 41631)

Check before ordering

GROUP K

ENGINE - Distributor Components 2.6 Litre Petrol
Up to Engine Suffix 'B' inclusive

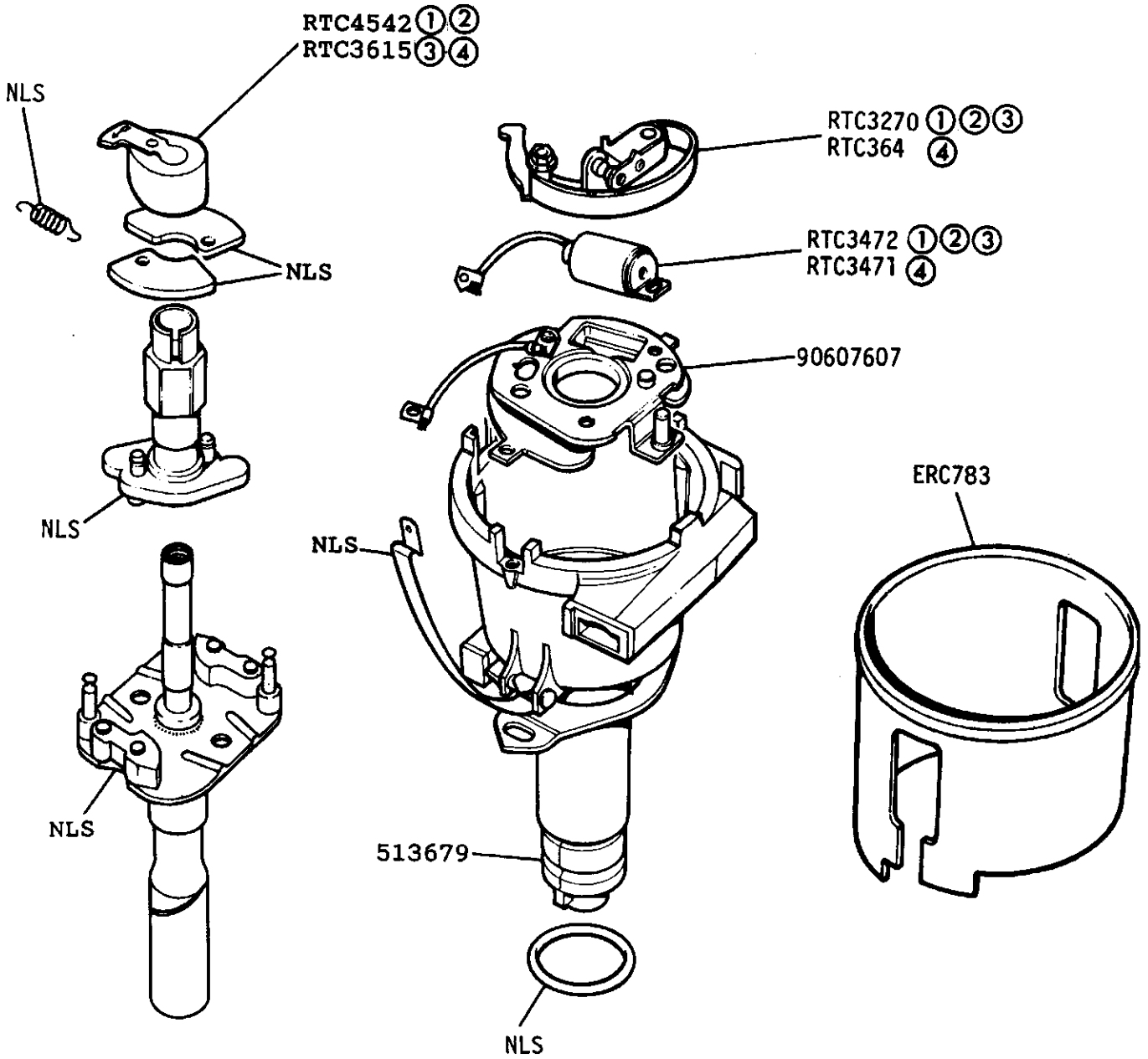

Distributor Complete AEU1124
Sundry Parts Kit NLS

- ① Use with Distributor 568729 Lucas 41227)
- ② Use with Distributor 597735 Lucas 41498)
- ③ Use with Distributor ERC545 Lucas 41585)
- ④ Use with Distributor AEU1124 Lucas 41631)

Check before ordering



LAND ROVER

2E 04

2RE 54

GROUP K
DETOXED ENGINE - Distributor Components 2.6 Litre Petrol From Engine Suffix 'C' onwards

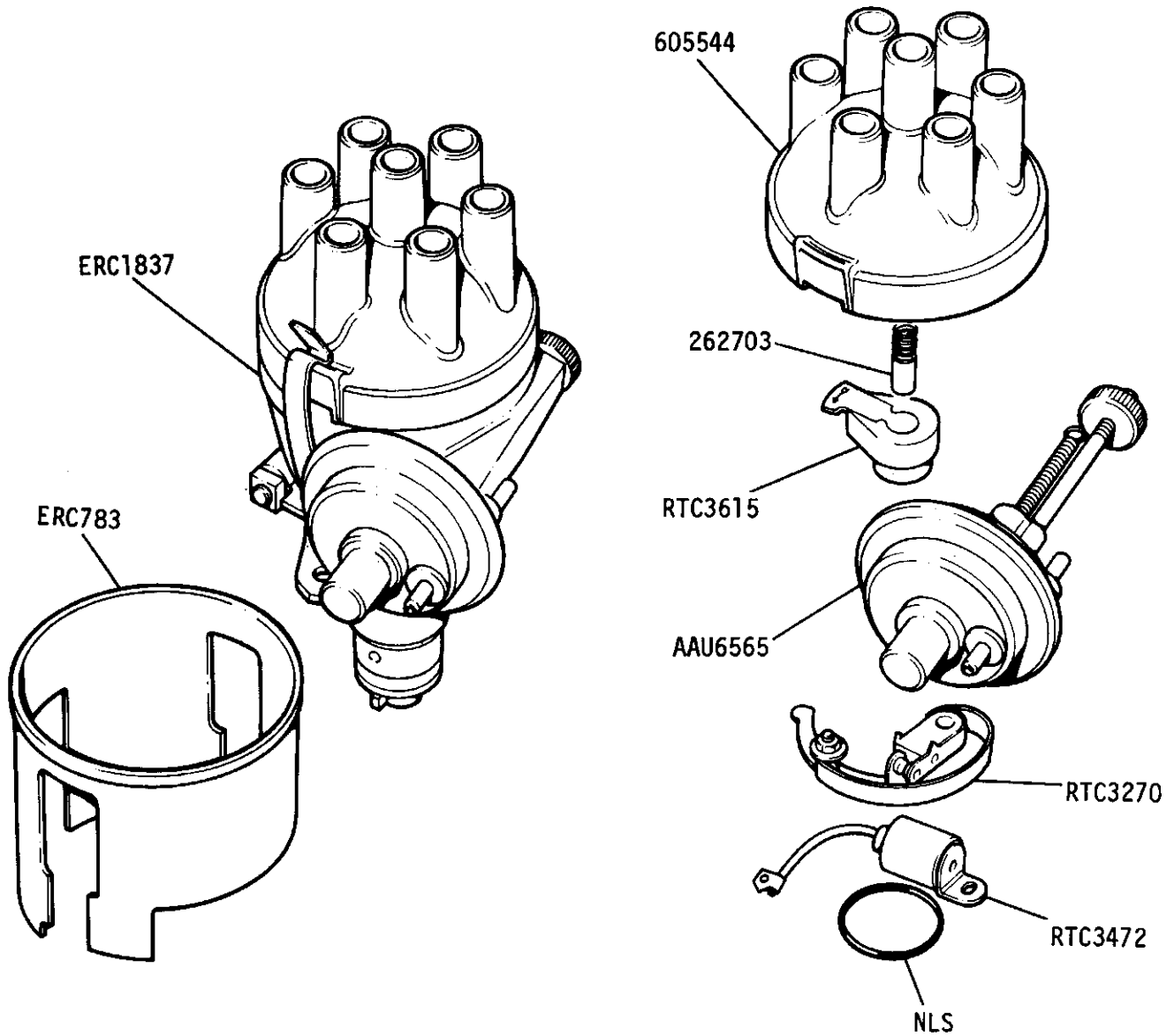

GROUP K

DETOXED ENGINE - Distributor Leads and Heat Shield 2.6 Litre Petrol

From Engine Suffix 'C' onwards

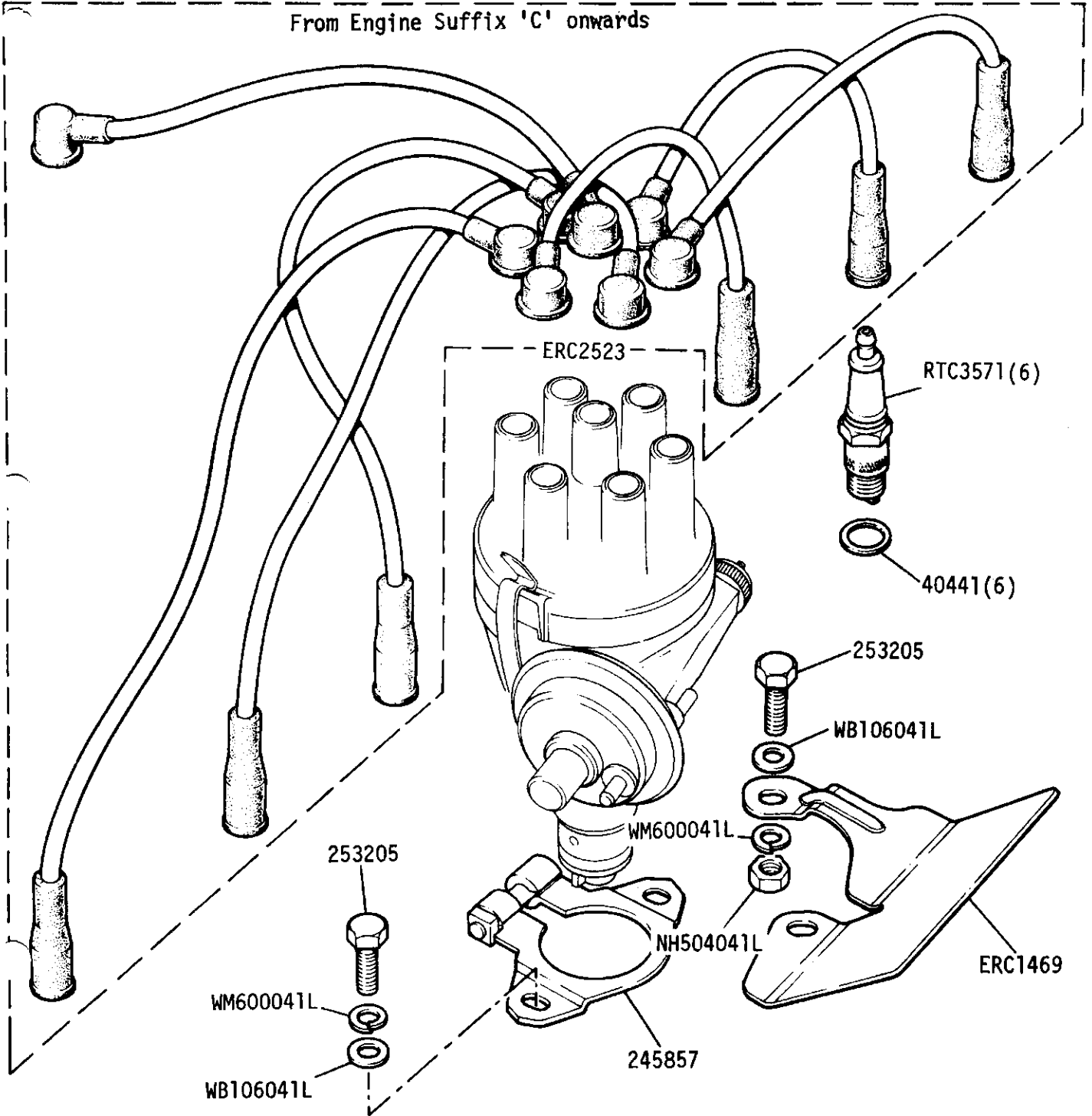

Distributor complete ERC1837